

May 21, 2026

Mr. Ryan Garland
Owner
Paradyme Investments LLC
43620 Ridge Park Drive, Suite 310
Temecula, CA 92590
breanna@paradymecompanies.com

Re: Paradyme Flats | Traffic Impact Statement
1926 Swanson Ave, Lake Havasu City, AZ 86403
APN 107-27-022A & 107-27-27A

1 INTRODUCTION

This Traffic Impact Statement (TIS) is prepared for the Paradyme Flats (Project) located at 1926 Swanson Avenue, Lake Havasu City, Arizona (City).

The Project will consist of a 4.49-acre vacant lot that will be developed with 68 dwelling units of townhome community as shown in the site plan (Attachment A). The Project is forecast to generate approximately 32 AM peak hour trips, 35 PM peak hour trips and 447 daily trips based on calculations performed using the Institute of Transportation Engineers (ITE) Trip Generation Manual, 12th Edition Land Use Code (LUC) 215 "Single-Family Attached Housing".

This TIS has been prepared in accordance with the Arizona Department of Transportation (ADOT) Traffic Impact Statement Guidelines for review and approval by the City.

The purpose of this study was to document existing conditions and the proposed Project site plan and document the results of the traffic signal warrant analysis at the study intersection, as well as calculate anticipated site-generated trips and trip distribution associated with the Project.

2 PROJECT BACKGROUND

The Project site is located on the southwest corner of Swanson Avenue and Smoketree Avenue in Lake Havasu City, Arizona, as shown in **Figure 1**. The site plan is shown in **Figure 2** and in **Attachment A**. The Project site is located on a vacant lot. The site is bounded by Swanson Avenue to the north, Smoketree Avenue to the east, Magnolia Drive to the south and residential units to the west.

The Project site access will be achieved through one (1) full-access driveway off of Swanson Avenue located approximately 450 feet west of Smoketree Avenue and one (1) full-access driveway off of Magnolia Drive located approximately 430 feet west of Smoketree Avenue.

The anticipated Project opening year is 2027.

Figure 1: Project Location



and one (1) shared through/right-turn lane; the westbound approach consists of one (1) dedicated left-turn lane and one (1) shared through/right-turn lane.

Smoketree Avenue/Magnolia Drive is a four-legged unsignalized intersection with stop control present on the eastbound and westbound approaches. The northbound approach consists of one (1) shared left-turn/through/right-turn lane; the southbound approach consists of one (1) left turn lane (via a TWLTL), and one (1) shared through/right-turn lane; the eastbound approach consists of one (1) shared left-turn/through/right-turn lane; the westbound approach consists of one (1) shared left-turn/through/right-turn lane.

3.3 Existing Traffic Volumes

24-hour turning movement counts were collected by Field Data Services (FDS) on Tuesday, March 31, 2026, at the intersection of Swanson Avenue/Smoketree Avenue. The traffic count data sheets are provided in **Attachment B**. The existing peak hour volumes are shown in **Figure 3**.

Figure 3: Existing Volumes

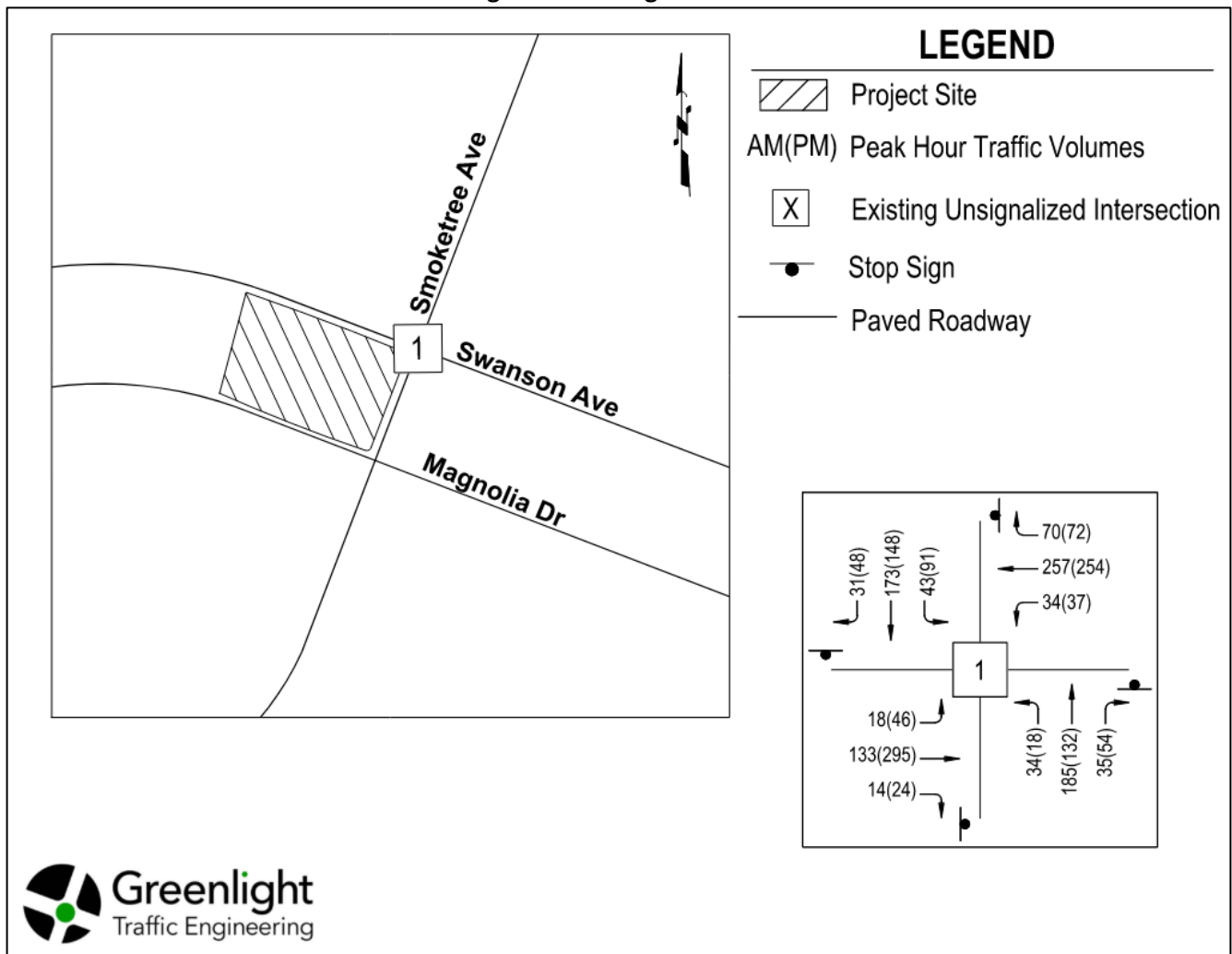

3.4 Roadway Safety

Crash data was obtained for the study area from the ADOT crash database for the years 2020-2024. A total of 22 crashes have occurred near Swanson Avenue and Smoketree Avenue. Intersection crashes were queried using a 150-foot buffer for unsignalized intersections.

Injury severity, collision manner, and first harmful event are summarized in **Table 1** through **Table 3**. No fatalities were observed at the intersections, and 59% of the incidents were no injury. Approximately 95% of the incidents

were the result of a rear-end, or a left turn/angle, which are common crash types at or on the approach to intersections.

Table 1: Crashes by Injury Severity

Injury Severity	2020	2021	2022	2023	2024	Grand Total
Swanson Avenue and Smoketree Avenue						
No Injury	1	5	1	4	2	13
Possible Injury	2	3	1	0	0	6
Suspected Minor Injury	1	0	1	0	0	2
Suspected Serious Injury	0	1	0	0	0	1
Grand Total	4	9	3	4	2	22

Table 2: Crashes by Collision Manner

Collision Manner	2020	2021	2022	2023	2024	Grand Total
Swanson Avenue and Smoketree Avenue						
Angle	3	6	3	1	2	15
Left Turn	0	1	0	2	0	3
Rear End	1	1	0	1	0	3
Other	0	1	0	0	0	1
Grand Total	4	9	3	4	2	22

Table 3: Crashes by First Harmful Event

First Harmful Event	2020	2021	2022	2023	2024	Grand Total
Swanson Avenue and Smoketree Avenue						
Motor Vehicle In Transport	3	8	3	4	2	20
Pedalcycle	1	1	0	0	0	2
Grand Total	4	9	3	4	2	22

4 PROPOSED SITE CONDITIONS

4.1 Site Access

Access to the Project will be provided via one (1) full access driveway off of Swanson Avenue located approximately 450 feet west of Smoketree Avenue and one (1) full access driveway off of Magnolia Drive located approximately 430 feet west of Smoketree Avenue.

4.2 Trip Generation

Trip generation is estimated using the Institute of Transportation Engineers (ITE) Trip Generation Manual, 12th Edition. The ITE Trip Generation Manual compiles real-world data collected nationwide by transportation professionals from various land uses. For each land-use category, the manual summarizes the data collection findings and develops average trip rates and predictive equations that relate to an associated independent variable (typically a measure of development size) to the number of generated trips for each land-use category.

The Project will be developed with 68 dwelling units of townhome community as shown in the site plan. Using ITE Land Use 215 “Single-Family Attached Housing,” the Project is forecast to generate approximately 32 AM peak hour trips, 35 PM peak hour trips, and 447 daily trips on a weekday.

Calculated trip values are shown in **Table 4**. A detailed trip generation calculation is provided in **Attachment C**.

Table 4: Project Trip Generation

Land Use	ITE Code	Size	Unit	AM Peak Hour			PM Peak Hour			Daily Volume
				In	Out	Total	In	Out	Total	
Single-Family Attached Housing	215	68	Dwelling Units	8	24	32	20	15	35	447
Total Trips				8	24	32	20	15	35	447

4.3 Trip Distribution and Assignment

The site-generated trips were distributed across the study area roadway network based on the assumptions shown in **Table 5** and in **Figure 4**.

Table 5: Trip Distribution

Roadway	Direction	Distribution	
		From Site	To Site
Swanson Avenue	West of Smoketree Avenue	20%	20%
Smoketree Avenue	North of Swanson Avenue	20%	20%
Swanson Avenue	East of Smoketree Avenue	20%	20%
Smoketree Avenue	South of Magnolia Drive	30%	30%
Magnolia Drive	West of Smoketree Avenue	10%	10%

The trip distribution shown in **Table 5** reflects assumptions about regional and local travel patterns expected to be associated with the Project. Approximately 60% of the site-generated trips are assumed to be destined to or originating from Arizona State Route 95 (SR-95), which serves as the primary regional route through Lake Havasu City and provides access to employment, commercial, and regional destinations. The remaining 40% of trips is assumed to account for local trip activity to the north and east of the Project site, including nearby retail, grocery, and other commercial and employment destinations.

The Project is situated within a generally fully developed area with a well-connected local roadway network, providing residents with multiple route options for entering and exiting the site. Additionally, as previously mentioned, Project site access will be achieved through one (1) full-access driveway off of Swanson Avenue and one (1) full-access driveway off of Magnolia Drive. Therefore, multiple routes are available from each site driveway to access SR-95 and the regional network, as well as local destinations surrounding the site.

Route choice by residents for ingress and egress is anticipated to be primarily influenced by trip origin/destination along with the most direct available route. Residents traveling to or from SR-95 and destinations to the west and south are anticipated to utilize Swanson Avenue and Smoketree Avenue segments, with Magnolia Drive available as an intermediate roadway to access these routes from the site driveway situated along Magnolia Drive. The majority of the trips destined to the west and south are not likely to travel through the intersection of Swanson Avenue and Smoketree Avenue. However, residents destined to/from the north and east will likely utilize the intersection of Swanson Avenue and Smoketree Avenue, as this is the most likely direct route to/from those areas.

Finally, Magnolia Drive also provides access to additional intersections to the west, which offer alternative routes back to Swanson Avenue via minor-street stop-controlled intersections. While these routes are available to drivers, they are assumed to see minimal use, as direct routes to Swanson Avenue and Smoketree Avenue will generally provide the most efficient access to the primary roadways and destinations in the area.

Site-generated trips were assigned to Project entrance and exit points based on available and reasonable routes. Site-generated trips are shown in **Figure 4**.

Figure 4: Site Generated Trips

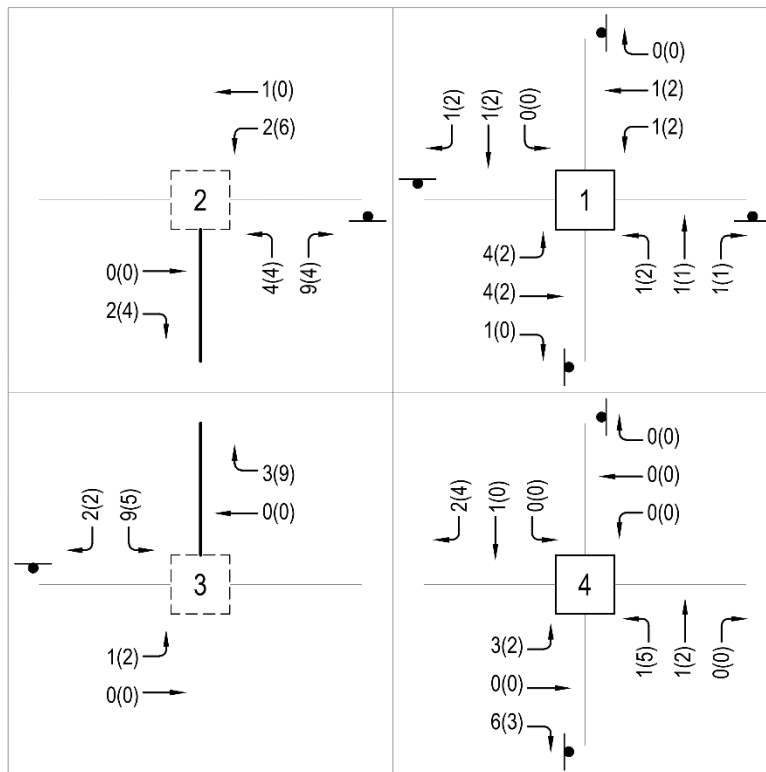
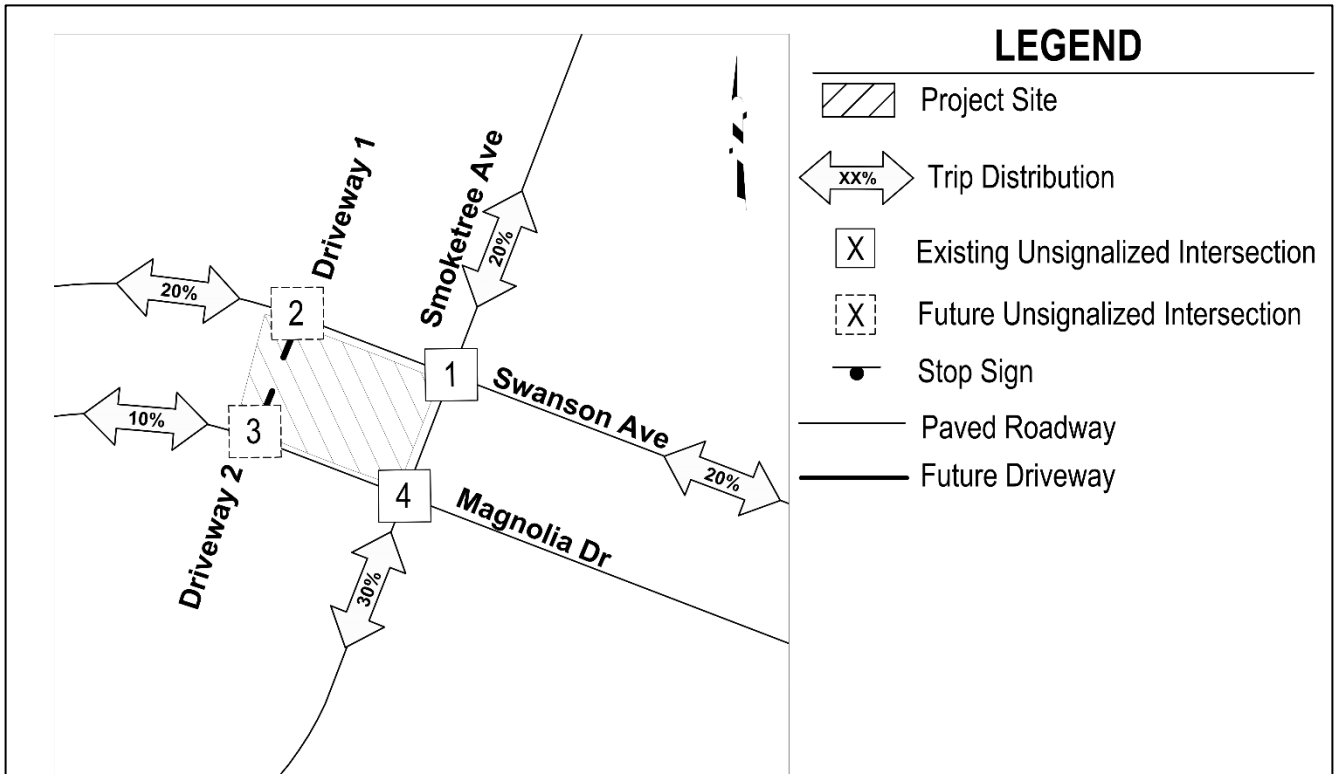

5 FUTURE CONDITIONS

5.1 Intersection Level of Service Analysis and Performance Threshold

LOS is a qualitative description of the traffic conditions at an intersection. Intersection LOS results are dependent upon the type of intersection control and the delay experienced at the intersection. Synchro 12 traffic analysis software was used to perform study intersection LOS calculations using the Highway Capacity Manual 7th Edition (HCM7) analysis methodology. The HCM methodology assigns a LOS value varying from LOS A (free-flow conditions) to LOS F (heavily congested conditions) to an intersection based on the delay experienced at the intersection. The delay and corresponding LOS values from HCM are shown in **Table 6**.

Table 6: Intersection LOS and Delay Values

LOS	Control Delay per Vehicle (seconds/vehicle)	
	Signalized Intersection	Unsignalized Intersection
A	0-10	0-10
B	>10-20	>10-15
C	>20-35	>15-25
D	>35-55	>25-35
E	>55-80	>35-50
F	>80	>50

Synchro 12 analysis summary sheets are provided in **Attachment D**.

5.2 Traffic Forecasting

Non-site traffic forecasting accounts for ambient growth of vehicle trips that occur on the roadway network adjacent to the Project site. As a conservative approach, the existing traffic volumes were increased by a growth rate of 3.0% per year to the opening year in order to obtain the non-site traffic volumes. Total traffic volumes were obtained by adding the estimated Project trips to the non-site traffic volumes.

5.3 Level of Service Analysis

5.3.1 Year 2027 LOS

The non-site and total traffic volumes for Year 2027 are shown on **Figure 5**.

Table 7 summarizes LOS results for the Year 2027 non-site and total AM and PM peak hour conditions.

Table 7: Year 2027 Peak Hour LOS



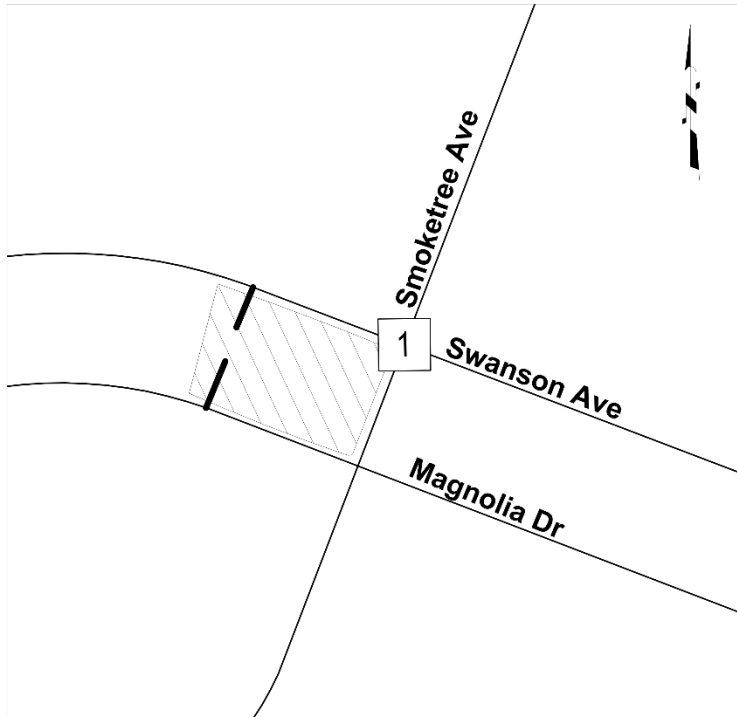

Int. No.	Movement	2027 Non-Site				2027 Total			
		AM Peak LOS	AM Peak Delay (sec)	PM Peak LOS	PM Peak Delay (sec)	AM Peak LOS	AM Peak Delay (sec)	PM Peak LOS	PM Peak Delay (sec)
Unsignalized Intersections									
All-Way Stop Control									
1	Smoketree Avenue/Swanson Avenue								
	NBL	B	11.8	B	13.1	B	12.0	B	13.3
	NBT/R	C	18.6	C	21.3	C	19.0	C	21.8
	SBL	B	12.1	C	15.7	B	12.2	C	15.9
	SBT	C	16.1	C	17.9	C	16.4	C	18.2
	SBR	B	10.4	B	12.2	B	10.5	B	12.3
	EBL	B	11.7	B	13.0	B	11.9	B	13.2
	EBT/R	C	15.1	E	41.4	C	15.5	E	43.3
	WBL	B	11.3	B	12.8	B	11.4	B	12.9
	WBT/R	D	27.3	E	42.8	D	28.2	E	44.2
	Intersection	C	19.3	D	30.5	C	19.8	D	31.4

As shown in **Table 7**, the study intersection is expected to maintain their respective LOS results for the Year 2027 AM and PM peak hour non-site and total traffic scenarios. Therefore, the proposed Project does not cause a decrease in LOS for any movement at the study intersection. While the EB and WB through/right-turn movements operate at LOS E during the PM peak hour, this occurs during both non-site and total traffic conditions, and the Project does not change the LOS grade for any movement at the intersection.

Figure 5: 2027 Nonsite and Total Traffic Conditions



LEGEND

-  Project Site
- AM(PM) Peak Hour Traffic Volumes
-  Existing Unsignalized Intersection
-  Stop Sign
-  Paved Roadway
-  Future Driveway

2027 Non-Site

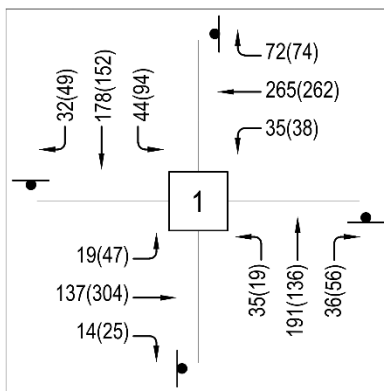

2027 Total

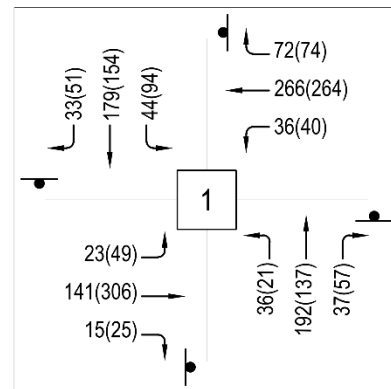

6 TRAFFIC SIGNAL WARRANT ANALYSIS

The Manual on Uniform Traffic Control Devices (MUTCD), 11th Edition, provides nine distinct traffic signal warrants that can be evaluated when considering installation of a traffic signal at an unsignalized intersection. If one or more of the warrants are met, a traffic signal should be considered for installation. **Table 8** below summarizes the warrants along with the applicability to the Project study intersection.

Table 8: MUTCD Warrants Summary

Warrant	Applicable?
Warrant 1: Eight-Hour Vehicular Volumes	Yes
Warrant 2: Four-Hour Vehicular Volumes	Yes
Warrant 3: Peak Hour	No
Warrant 4: Pedestrian Volume	No
Warrant 5: School Crossing	No
Warrant 6: Coordinated Signal System	No
Warrant 7: Crash Experience	Yes
Warrant 8: Roadway Network	No
Warrant 9: Intersection Near a Grade Crossing	No

A traffic signal warrant analysis was performed for the study intersection using Warrants 10 software for the existing traffic conditions. The traffic signal Warrants 10 summary reports can be found in **Attachment E**.

Warrant 1 Eight Hour Vehicular Volumes

Warrant 1, Eight-Hour Vehicle Volume is satisfied when one of the following conditions is met:

- Condition 1 A, Eight-Hour Vehicular Volume - Minimum Vehicular Volume
- Condition 1 B, Eight-Hour Vehicular Volume - Interruption of Continuous Traffic

Condition 1 A is intended for application at locations where a large volume of intersecting traffic is the principal reason to consider installing a traffic control signal. MUTCD Table 4C-1 specifies the conditions that need to be met for the warrant to be satisfied. The warrant is met when the condition is met 8 hours on an average day.

Condition 1 B is intended for application at locations where Condition A is not satisfied and where the traffic volume on a major street is so heavy that traffic on a minor intersecting street suffers excessive delay or conflict in entering or crossing the major street. MUTCD Table 4C-1 specifies the conditions that need to be met for the warrant to be satisfied for Condition 1 B.

The traffic signal Warrants 10 summary reports for Warrant 1 can be found in **Attachment E**.

Nine (9) hours are met for Warrant 1, therefore, Warrant 1 is met.

Warrant 2 Four-Hour Vehicular Volume

Warrant 2 is intended to be applied where the volume of intersecting traffic is the principal reason to consider installing a traffic signal control. Warrant 2 states that “The need for a traffic control signal shall be considered if an engineering study finds that, for each of any 4 hours of an average day, the plotted points representing the vehicles per hour on the major street (total of both approaches) and the corresponding vehicles per hour on the more critical minor-street approach (one direction only) all fall above the applicable curve in MUTCD Figure 4C-1 for the existing combination of approach lanes. On the minor street, the more critical volume is not required to be on the same approach during each of these 4 hours.”

The traffic signal Warrants 10 summary reports for Warrant 2 can be found in **Attachment E**.

Five (5) hours are met for Warrant 2, therefore, Warrant 2 is met.

Warrant 7 Crash Experience

The Crash Experience signal warrant conditions are intended for application where the severity and frequency of crashes are the principal reasons to consider installing a traffic control signal.

The need for a traffic control signal should be considered if an engineering study finds that all of the following criteria are met:

A. Adequate trial of alternatives with satisfactory observance and enforcement has failed to reduce the crash frequency; and

B. At least one of the following conditions applies to the reported crash history (where each reported crash considered is related to the intersection and apparently exceeds the applicable requirements for a reportable crash):

1. The number of reported angle crashes and pedestrian crashes within a 1-year period equals or exceeds the threshold number in Table 4C-2 for total angle crashes and pedestrian crashes (all severities); or

2. The number of reported fatal-and-injury angle crashes and pedestrian crashes within a 1-year period equals or exceeds the threshold number in Table 4C-2 for total fatal-and-injury angle crashes and pedestrian crashes; or

3. The number of reported angle crashes and pedestrian crashes within a 3-year period equals or exceeds the threshold number in Table 4C-3 for total angle crashes and pedestrian crashes (all severities); or

4. The number of reported fatal-and-injury angle crashes and pedestrian crashes within a 3-year period equals or exceeds the threshold number in Table 4C-3 for total fatal-and-injury angle crashes and pedestrian crashes; and

C. For each of any 8 hours of an average day, the vehicles per hour (vph) given in both of the 80 percent columns of Condition A in Table 4C-1 (see Section 4C.02), or the vph in both of the 80 percent columns of Condition B in Table 4C-1 exists on the major street and the more critical minor-street approach, respectively, to the intersection, or the volume of pedestrian traffic is not less than 80 percent of the requirements specified in the Pedestrian Volume warrant (see Section 4C.05).

Typical crashes correctable with the installation of a traffic signal include angle crashes. As noted in the MUTCD, "Angle crashes include all crashes that occur at an angle and involve one or more vehicles on the major street and one or more vehicles on the minor street"

Table 9: Warrant 7 Crash Experience Results

Criteria A	Criteria B	Criteria C	Warrant Met?
Met?	Met?	Met?	Met?
Not Evaluated	SIX (6) CRASHES IN 12 MONTH PERIOD AND 12 CRASHES IN A 3-YEAR PERIOD	11 HOURS MET FOR CONDITION 1 A (80%)	No*

**Note: Criteria A (adequate trial of alternatives) was not evaluated as part of this Traffic Impact Statement. However, Criteria B and C are met based on the existing crash history and traffic volumes, respectively. Should Criteria A subsequently be determined to be satisfied, Warrant 7 would be met.*

Traffic Signal Warrant Summary

Table 10: MUTCD Warrants Results Summary

Warrant	Met?
Warrant 1: Eight-Hour Vehicular Volumes	Yes
Warrant 2: Four-Hour Vehicular Volumes	Yes
Warrant 7: Crash Experience	No*

*Criteria A not evaluated

Based on the results of the traffic signal warrant analysis shown in **Table 10**, a traffic signal is warranted at Swanson Avenue/Smoketree Avenue based on the existing traffic volumes, as Warrant 1 and Warrant 2 are satisfied.

As previously noted, for Warrant 7, Criteria A (adequate trial of alternatives) was not evaluated as part of this Traffic Impact Statement. However, Criteria B and C are met based on the existing crash history and traffic volumes, respectively. Should Criteria A subsequently be determined to be satisfied, Warrant 7 would be met.

Per the MUTCD, the satisfaction of a traffic signal warrant or warrants shall not in itself require the installation of a traffic control signal.

7 CONCLUSIONS AND RECOMMENDATIONS

The following conclusions are made based on the findings of the Project TIS:

1. The Project is expected to generate approximately 32 AM peak hour, 35 PM peak hour and 447 daily trips.
2. The Project is not expected to have a significant impact to the surrounding roadway infrastructure as it is expected to generate under 100 peak hour trips.
3. The Smoketree Avenue/Swanson Avenue study intersection is expected to maintain its respective LOS results for the Year 2027 AM and PM peak hour non-site and total traffic scenarios.
4. Based on the traffic signal warrant analysis using the existing traffic volumes, Warrants 1 and 2 are met and a traffic signal is warranted at Swanson Avenue/Smoketree Avenue. The signal warrants are met under existing conditions and are not a result of the proposed Project.
 - a. Per the MUTCD, the satisfaction of a traffic signal warrant or warrants shall not in itself require the installation of a traffic control signal.

In summary, the proposed Project is not anticipated to have a significant impact on the adjacent roadway network. The following recommendations were developed based on the findings of the Project TIS:

1. Design and construction of the proposed Project improvements should conform to Lake Havasu City design guidelines, as applicable.

Sincerely,
Greenlight Traffic Engineering, LLC



Grant Treinen, PE
Senior Project Engineer
grantt@greenlightte.com
(480) 889-4264



Attachments:

- A – Paradyme Flats Site Plan
- B – Traffic Volumes
- C – Trip Generation Calculations
- D – Synchro 12 Reports
- E – Warrants 10 Report
- F – Response to Comments (1st Submittal)

ATTACHMENTS

ATTACHMENT A

Preliminary
NOT FOR CONSTRUCTION

DRAWINGS AND SPECIFICATIONS REMAIN THE PROPERTY OF THE DESIGN PROFESSIONAL. COPIES OF THE DRAWINGS AND SPECIFICATIONS MAY BE MADE BY THE CLIENT FOR THE PROJECT FOR WHICH THEY WERE PREPARED, AND NOT FOR THE CONSTRUCTION OF ANY OTHER PROJECTS.

PROJECT NAME: **PARADYME FLATS - TOWNHOMES COMMUNITY**
PHASE I: BLDG. 'A'
 1926 SWANSON AVE., 1851 MAGNOLIA DR LAKE HAVASU CITY, AZ 86403
 TRACT: 2304 BLK: 1 LOTS: 18 - 22, 23 - 27

ARCHITECT OF RECORD
SELBERG ASSOCIATES INC.
 ARCHITECTURE & PLANNING
 2130 MESQUITE AVE | SUITE 204
 LAKE HAVASU CITY | ARIZONA | 86403
 (928) 855-9244

PROJECT NO. 25069
 ISSUED FOR: PERMIT SET
 ISSUED DATE: MARCH 5, 2026
 REVISION: ISSUE DATE

SHEET TITLE: ARCHITECTURAL SITE PLAN
 SHEET NO. **A1.01**

GENERAL SITE NOTES:

- ALL PROPERTY LINES, EASEMENTS AND BUILDINGS ARE SHOWN ON THIS SITE PLAN.
- ACCESSIBLE ROUTE - ALL WALKS, HALLS, CORRIDORS, AISLES AND OTHER SPACES THAT ARE PART OF AN ACCESSIBLE ROUTE SHALL COMPLY WITH THE MINIMUM STANDARDS SET FORTH IN THE ADAAG.
- PROTRUDING OBJECTS - PROTRUDING OBJECTS SHALL NOT REDUCE THE CLEAR WIDTH OF AN ACCESSIBLE ROUTE OR MANEUVERING SPACE.
- PARKING & TRAFFIC STRIPING PARKING DESIGNATIONS TO BE 4" WIDE WHITE.
- ACCESS AISLE MUST BE CLEARLY MARKED WITH DIAGONAL STRIPES SPACED 2 FT. ON CENTER.
- THE ACCESSIBLE SPACE SHALL BE IDENTIFIED BY A STANDARD REGULATORY SIGN (8.80 REFLECTIVE ALUMINUM WITH BLUE LETTERS ON A WHITE BACKGROUND). THE SIGN SHALL BE MOUNTED ON A CUSTOM DECORATIVE POST, OR ON A WALL IF LOCATED WITHIN 4 FEET OF THE EDGE OF A SIDEWALK. THE HEIGHT SHALL NOT BE MORE THAN 7 FT. ABOVE GRADE LEVEL.

UNIT BREAKDOWN

	TYPE 1 UNIT	TYPE 2 UNIT	TYPE 3 UNIT	TYPE 4 UNIT
BUILDING 'A'	10	-	-	-
BUILDING 'B'	-	12	-	-
BUILDING 'C'	-	-	11	-
BUILDING 'D'	-	6	-	-
BUILDING 'E'	-	6	-	-
BUILDING 'F'	-	-	-	12
BUILDING 'G'	-	-	11	-
TOTAL = 68	10	24	22	12

PARKING CALCULATION:

REQUIREMENTS IN DISTRICT:
 1.5 SPACES PER UNIT CONTAINING 1 BEDROOM
 2 SPACES PER UNIT CONTAINING 2 OR MORE BEDROOMS

DWELLING UNITS PARKING:
 BUILDING 'A' - 3-BEDROOM - 2 SPACES REQUIRED X 10 UNITS = 20 SPACES
 BUILDING 'B' - 2-BEDROOM - 2 SPACES REQUIRED X 12 UNITS = 24 SPACES
 BUILDING 'C' - 1-BEDROOM - 1.5 SPACES REQUIRED X 11 UNITS = 16.5 SPACES
 BUILDING 'D' - 2-BEDROOM - 2 SPACES REQUIRED X 6 UNITS = 12 SPACES
 BUILDING 'E' - 2-BEDROOM - 2 SPACES REQUIRED X 6 UNITS = 12 SPACES
 BUILDING 'F' - 1-BEDROOM - 1.5 SPACES REQUIRED X 12 UNITS = 18 SPACES
 BUILDING 'G' - 1-BEDROOM - 1.5 SPACES REQUIRED X 11 UNITS = 16.5 SPACES

TOTAL SUM OF ALL BUILDINGS - 116 SPACES REQUIRED

VISITOR PARKING:
 68 UNITS / 5 = 14 = 14 PARKING SPACES

- OVERALL TOTAL PARKING REQUIRED = 130 SPACES (INCLUDES 116 REQUIRED DWELLING UNIT PARKING AND 14 REQUIRED VISITOR PARKING)
 - ACCESSIBLE SPACES REQUIRED DUE TO VISITOR SPACES: 1 SPACE

PROVIDED: 130 PARKING SPACES (116 DWELLING UNIT PARKING, 13 STANDARD VISITOR PARKING AND 1 ACCESSIBLE VISITOR PARKING SPACE).

LANDSCAPE CALCULATION:

LOT AREA APN 107-27-022A = 120,661 SQ. FT. (2.77 ACRES) TOTAL = 195,584 SQ. FT. (4.49 ACRES)
 LOT AREA APN 107-27-027A = 74,923 SQ. FT. (1.72 ACRES)
 CITY REQUIREMENT IS 20% NET OF LANDSCAPE, FOR R-CHD ZONING DISTRICT.
 20% NET SITE AREA = 0.20 X 195,584 SQ. FT.
 LANDSCAPE AREA REQUIRED = 39,117 SQ. FT.

TOTAL LANDSCAPE AREA PROVIDED = 32,390 SQ. FT.

• PARKING LANDSCAPING REQUIREMENT:
 1 LANDSCAPE AREA REQUIRED EVERY 15 PARKING SPACES - 26 PARKING SPACES / 15 = 1.73 = 2 LANDSCAPE AREAS
 2 LANDSCAPE AREAS
 1 TREE REQUIRED FOR EVERY 300 SQ. FT.
 245 SQ. FT. OF 32,390 SQ. FT. TOTAL DEDICATED TO PROVIDED PARKING SPACES
 3 TREES AND 20 SHRUBS OF TOTAL COUNT DEDICATED TO PROVIDED PARKING SPACES

• FRONTAGE LANDSCAPING REQUIREMENT:
 1 TREE PER 40 FT = 583/40 = 14.6 = 15 TREES
 1 SHRUB PER 25 FT = 583/25 = 23.32 = 24 SHRUBS

TOTAL REQUIRED = 15 TREES, 24 SHRUBS

SYM.	BOTANICAL NAME	COMMON NAME	QTY.	SIZE
☼	ACACIA ANURA	MULGA ACACIA	68	24" BOX
☼	LEUCOPHYLLUM FRUTESCENS	TEXAS SAGE	65	36" BOX
☼	PHOENIX DACTYLIFERA	DATE PALM	36	5 GAL
■		12" MINUS DECOMPOSED GRANITE - BROWN		
■		12" MINUS DECOMPOSED GRANITE - RED		

LANDSCAPE NOTES:

- CONTRACTOR SHALL PROVIDE BACKFLOW PREVENTION SYSTEM FOR LANDSCAPE
- ALL PLANTED AREAS SHALL BE COVERED WITH 3/8" MIN. DECORATIVE ROCK SIZE AND COLOR PER PLANTING LEGEND.
- ALL PLANTING SHALL BE ON AN AUTOMATIC DRIP SYSTEM.
- LANDSCAPE CONTRACTOR SHALL SUBMIT IRRIGATION PLAN FOR COMPLETE IRRIGATION SYSTEM FOR PLANTING AREAS TO GENERAL CONTRACTOR FOR APPROVAL.
- ALL IRRIGATION PIPING SHALL BE COVERED AT A 6" BURIAL DEPTH.
- ALL IRRIGATION PIPING UNDER CONCRETE SHALL BE SLEEVED AT A 24" BURIAL DEPTH AND BACKFILLED WITH BUILDER'S SAND AND COMPACTED TO MINIMUM 90%.
- ALL PLANTS SHALL HAVE A WATERING BASIN FORMED FROM EARTH BUILT AROUND THE BASE OF THE PLANT.
- INSTALL ROOT BARRIERS AT ALL TREES WITHIN 5'-0" OF SIDEWALKS.

DESIGN AND ILLUMINATION STANDARDS:

ALL LIGHTING SHALL BE DESIGNED AND ILLUMINATED IN ACCORDANCE TO THE ARTICLE 14.04.05 C, PER LHS DEVELOPMENT CODE.

- LIGHTING HEIGHT:
 - THE MAX HEIGHT FOR ALL DISTRICTS OR USES (EXCEPT U AND I) WILL BE 20 FT.
 - THE MAX HEIGHT FOR DISTRICTS U AND I WILL BE 30 FT.
- LIGHT SHIELDING:
 - ANY LIGHT SOURCE OR LAMP THAT EMITS MORE THAN 375 LUMENS (25 WATTS INCANDESCENT OR 7 WATTS COMPACT FLUORESCENT) SHALL BE CONCEALED OR SHIELDED WITH AN IESNA FULL CUT-OFF STYLE FIXTURE WITH AN ANGLE NOT EXCEEDING 90 DEGREES TO MINIMIZE THE POTENTIAL FOR GLARE AND UNNECESSARY DIFFUSION ON ADJACENT PROPERTY.
 - BARE INCANDESCENT LIGHTS BULBS SHALL NOT BE PERMITTED IN VIEW OF ADJACENT PROPERTY OR PUBLIC RIGHT-OF-WAY. WALL MOUNTED LIGHTS SHALL BE DIRECTLY DOWNWARD, SOFFIT OR CANOPY MOUNTED LIGHT FIXTURES SHALL BE RECESSED IN THE SOFFIT OR OTHERWISE FULLY SHIELDED.
- NEON LIGHTING:
 - AS BUILDING ACCENT LIGHTING MAY BE PROVIDED IN COMPLIANCE WITH THE FOLLOWING CRITERIA:
 - NEON LIGHTING MAY BE USED TO ACCENT ARCHITECTURAL BUILDING ELEMENTS, EXCEPT THAT VERTICAL BANDS MAY NOT BE USED ALONG BUILDING CORNERS.
 - NEON LIGHTING SHALL BE A MINIMUM OF 6" BELOW THE TOP OF THE PARAPET OR ROOF EAVE LINE AND SHALL NOT BE ON TOP OF THE PARAPET OR ABOVE THE EAVE OR ALONG ROOF RIPS AND RIDGE LINES.
 - NEON LIGHTING SHALL ONLY BE USED ON BUILDING ELEVATIONS FACING RESIDENTIAL ZONING DISTRICTS WHERE A PUBLIC RIGHT-OF-WAY OF AT LEAST 70 FT.
 - NEON LIGHTING SHALL NOT BE USED WITH REFLECTIVE BACKGROUNDS THAT INTENSIFY THE EMITTED LIGHT.
 - NEON LIGHTING SHALL BE KEPT IN GOOD REPAIR AT ALL TIMES.

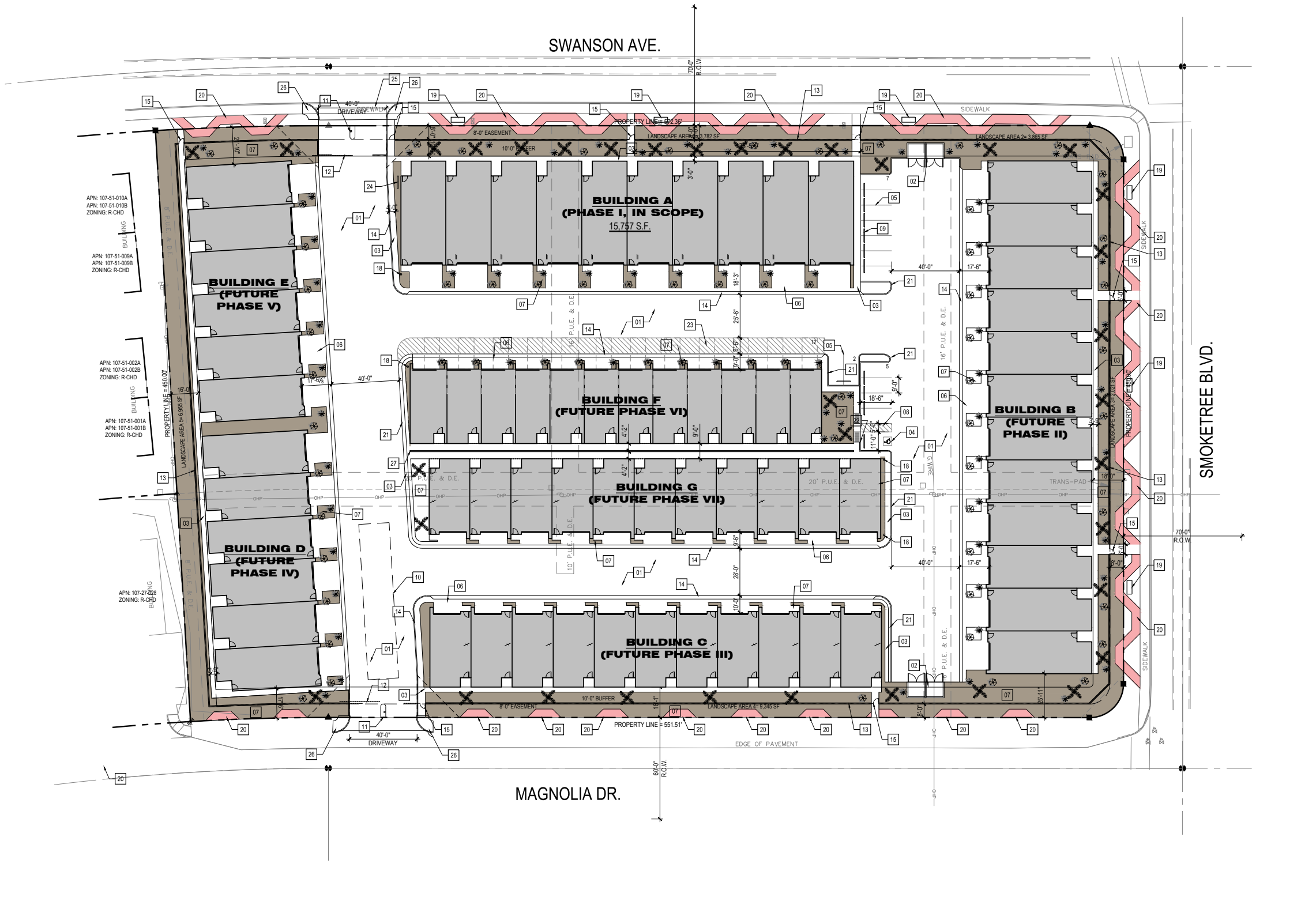

1 ARCHITECTURAL SITE PLAN
 1" = 30'

SITE KEYNOTES - CONTINUED

15	MAN GATE PER DETAIL 1 ON SHEET A1.02
16	WATER METER PER CIVIL DWGS.
17	IRRIGATION METER 3/4" W/ BACKFLOW PREVENTER
18	STEEL PIPE BOLLARDS PER DETAIL 5 ON SHEET A1.02
19	LEVIT GROUND MOUNTED BENCH BY LANDSCAPE FORMS - 79" X 28" MODEL OR APPROVED EQUAL BY OWNER
20	RED DECORATIVE LANDSCAPE ROCK SEPARATED BY ADJACENT LANDSCAPING BY PVC MOW EDGING
21	TYPICAL VERTICAL CURB
22	POLE MOUNTED SIGNAGE INDICATING RESERVED DESIGNATION ACCESSIBILITY PER DETAIL 7 ON SHEET A1.02
23	STRIPED AREA INDICATES PARKING FOR BUILDING 'F'
24	ELECTRICAL SERVICE ENTRANCE AND UNIT METERS
25	PORTION OF EXISTING SIDEWALK TO BE REMOVED
26	SIDEWALK RAMP PER CIVIL DRAWINGS
27	RETAINING WALL PER CIVIL DRAWINGS
28	

SITE KEYNOTES

01	PAVING PER CIVIL DRAWINGS
02	TRASH ENCLOSURE W/ STUCCO FINISH TO MATCH PRIMARY BUILDING COLOR, W/ WROUGHT IRON GATE. SEE DETAIL 8 ON SHEET A1.02
03	4" CONCRETE SIDEWALK 0/4" COMPACTED A.B.C. FILL
04	TYP. PAINTED INTERNATIONAL SYMBOL OF ACCESSIBILITY.
05	4" WIDE PAINTED PARKING STRIPING, TYPICAL
06	DRIVEWAY PER CIVIL DWGS.
07	PROPOSED LANDSCAPE AREA
08	PAINTED 5'-0" WIDE X 18'-6" LONG ACCESSIBLE ACCESS AISLE, SLOPE NOT TO EXCEED 2% IN ANY DIRECTION
09	6" X 8'-0" LONG PRECAST CONCRETE BUMPER
10	UNDERGROUND RETENTION BASIN PER CIVIL DWGS.
11	CONCRETE ISLAND WITH MOUNTED GATE ACCESS PANEL PER DETAIL 13 ON SHEET A1.02
12	STEEL SECURITY GATE
13	DECORATIVE CMU SCREEN WALL PER DETAIL 6 ON SHEET A1.02
14	ROLL CURB PER CIVIL DWGS.

ATTACHMENT B

Intersection Turning Movement

Prepared by:



FIELD DATA SERVICES OF ARIZONA, INC.
520.316.6745



veracitytrafficgroup

N-S STREET: Smoketree Ave

DATE: 03/31/26

LOCATION: Lake Havasu City

E-W STREET: Swanson Ave

DAY: TUESDAY

PROJECT# 26-1265-001

	NORTHBOUND			SOUTHBOUND			EASTBOUND			WESTBOUND			
LANES:	NL 1	NT 0.5	NR 0.5	SL 1	ST 1	SR 1	EL 1	ET 1	ER 0	WL 1	WT 1	WR 0	TOTAL
12:00 AM	0	0	3	1	2	0	1	2	0	0	2	0	11
12:15 AM	0	1	1	0	1	0	0	3	0	1	2	0	9
12:30 AM	0	2	0	0	2	0	0	0	1	0	2	0	7
12:45 AM	0	0	0	0	1	1	1	3	0	0	0	0	6
1:00 AM	0	1	0	0	1	0	1	4	0	0	1	0	8
1:15 AM	0	1	1	0	0	0	0	1	0	1	0	1	5
1:30 AM	0	1	0	0	0	0	0	1	0	1	0	1	4
1:45 AM	0	1	0	0	0	0	0	0	0	0	3	0	4
2:00 AM	0	0	0	0	0	0	0	2	0	0	7	0	9
2:15 AM	0	1	0	0	0	0	1	1	0	0	3	0	6
2:30 AM	0	0	0	0	0	1	0	0	0	1	2	0	4
2:45 AM	1	1	0	0	0	1	0	1	0	2	2	0	8
3:00 AM	0	0	0	0	1	0	1	0	0	0	0	0	2
3:15 AM	0	0	1	0	1	2	0	0	0	0	1	0	5
3:30 AM	0	1	0	0	0	0	1	2	0	0	0	1	5
3:45 AM	0	2	0	0	0	0	1	0	0	1	3	1	8
4:00 AM	1	2	0	0	4	0	0	2	0	2	1	0	12
4:15 AM	0	3	1	0	3	2	1	1	0	0	6	3	20
4:30 AM	0	1	2	1	0	0	0	2	1	3	3	0	13
4:45 AM	1	0	1	0	3	6	0	6	0	0	17	1	35
5:00 AM	2	5	0	2	7	2	1	6	0	1	8	0	34
5:15 AM	2	1	0	0	14	3	1	3	0	1	11	5	41
5:30 AM	0	5	3	1	13	2	1	3	2	1	11	1	43
5:45 AM	1	6	3	5	14	2	5	4	1	1	26	6	74
6:00 AM	2	19	2	3	16	4	6	8	2	2	21	4	89
6:15 AM	2	9	2	1	13	3	2	11	1	1	27	2	74
6:30 AM	2	14	0	2	10	3	5	11	0	4	30	5	86
6:45 AM	4	23	3	6	21	1	2	10	2	7	34	5	118
7:00 AM	4	17	8	4	21	5	5	21	2	1	25	6	119
7:15 AM	6	33	5	6	24	8	5	32	2	6	39	8	174
7:30 AM	5	57	4	13	40	8	2	22	2	7	55	11	226
7:45 AM	14	59	8	8	55	4	7	42	4	10	94	21	326
8:00 AM	6	38	12	7	46	5	2	33	5	13	69	20	256
8:15 AM	9	31	11	15	32	14	7	36	3	4	39	18	219
8:30 AM	8	27	8	19	30	12	9	32	3	11	48	14	221
8:45 AM	5	38	10	19	32	2	9	38	8	13	65	25	264
9:00 AM	6	42	13	14	32	5	9	45	6	11	67	20	270
9:15 AM	12	42	13	17	40	14	18	64	5	8	66	16	315
9:30 AM	8	31	11	18	43	9	5	55	4	11	72	17	284
9:45 AM	6	42	13	24	39	16	14	69	5	18	76	16	338
10:00 AM	10	39	7	15	31	21	9	72	8	9	60	24	305
10:15 AM	5	31	11	31	39	8	12	53	2	8	80	26	306

Intersection Turning Movement

Prepared by:

10:30 AM	8	39	10	21	26	20	18	69	5	7	61	20	304
10:45 AM	15	46	8	29	33	16	12	68	6	15	75	25	348
11:00 AM	4	33	13	39	34	11	12	60	3	11	59	21	300
11:15 AM	4	32	16	23	35	14	7	68	6	17	68	22	312
11:30 AM	9	32	13	36	39	15	10	76	7	12	72	28	349
11:45 AM	5	39	20	25	33	16	11	78	4	19	73	27	350
12:00 PM	12	34	17	25	35	18	11	78	13	16	86	23	368
12:15 PM	9	32	18	29	44	9	9	70	10	10	65	18	323
12:30 PM	13	39	12	24	28	12	8	69	8	13	78	19	323
12:45 PM	14	40	11	27	31	13	12	68	6	13	70	25	330
1:00 PM	7	31	12	34	34	15	15	80	8	12	74	17	339
1:15 PM	11	41	12	19	40	13	11	71	5	10	69	17	319
1:30 PM	7	25	12	23	34	14	10	75	9	13	50	18	290
1:45 PM	7	38	14	25	30	16	10	95	6	10	90	25	366
2:00 PM	5	41	20	35	25	12	15	81	10	11	65	21	341
2:15 PM	5	48	23	28	37	13	17	84	13	15	64	18	365
2:30 PM	6	36	15	27	48	16	3	63	7	12	69	15	317
2:45 PM	2	35	12	20	53	23	9	80	9	9	77	15	344
3:00 PM	9	40	8	30	40	16	8	82	7	8	83	24	355
3:15 PM	7	40	17	33	36	14	9	83	4	11	58	19	331
3:30 PM	5	38	14	21	33	16	7	79	6	10	64	17	310
3:45 PM	13	46	22	25	40	12	9	65	8	15	63	14	332
4:00 PM	3	37	12	29	33	7	9	68	10	14	66	16	304
4:15 PM	4	38	11	23	38	9	10	75	5	13	57	22	305
4:30 PM	4	31	12	22	31	14	10	72	8	4	66	22	296
4:45 PM	5	39	12	23	35	11	15	63	6	7	57	10	283
5:00 PM	5	24	19	23	44	14	11	85	5	13	74	18	335
5:15 PM	11	28	13	26	41	11	9	53	6	18	49	12	277
5:30 PM	5	27	10	18	29	8	10	62	8	8	53	14	252
5:45 PM	3	29	9	24	43	7	9	59	6	11	44	10	254
6:00 PM	2	33	14	14	42	10	5	53	3	10	45	9	240
6:15 PM	1	20	15	6	19	8	7	50	5	14	35	4	184
6:30 PM	4	17	9	11	24	7	11	38	3	5	34	6	169
6:45 PM	0	42	20	16	21	1	5	55	8	9	32	15	224
7:00 PM	1	26	10	11	15	14	6	45	3	11	31	7	180
7:15 PM	1	17	8	7	18	11	7	35	3	4	21	7	139
7:30 PM	1	9	9	9	16	7	8	33	1	2	19	7	121
7:45 PM	1	23	4	10	12	2	13	27	2	4	19	5	122
8:00 PM	1	16	9	8	11	8	4	30	2	2	23	3	117
8:15 PM	0	14	9	3	18	4	11	18	0	4	17	4	102
8:30 PM	2	11	5	5	13	6	4	24	0	4	11	2	87
8:45 PM	2	12	3	1	15	1	2	20	2	4	12	2	76
9:00 PM	1	15	2	5	6	1	3	17	2	6	5	4	67
9:15 PM	1	10	2	4	7	1	4	21	0	1	15	1	67
9:30 PM	2	7	5	3	6	0	2	26	1	3	16	3	74
9:45 PM	0	5	4	1	8	2	1	14	3	3	7	0	48
10:00 PM	1	5	4	3	4	0	1	11	1	0	7	0	37
10:15 PM	1	8	3	2	6	0	4	12	0	1	6	0	43
10:30 PM	0	5	3	3	3	3	3	6	0	1	4	0	31
10:45 PM	0	5	2	1	4	1	1	7	1	1	6	1	30
11:00 PM	0	7	3	2	4	2	0	8	0	2	3	1	32
11:15 PM	0	4	0	2	3	0	0	11	1	2	3	1	27
11:30 PM	0	1	1	2	0	0	3	6	1	0	0	0	14
11:45 PM	0	1	1	0	2	2	1	1	0	1	2	0	11

TOTAL	NL	NT	NR	SL	ST	SR	EL	ET	ER	WL	WT	WR	TOTAL
Volumes	361	2018	719	1147	1990	660	566	3448	325	611	3450	932	16227

Intersection Turning Movement

Prepared by:

Approach %	11.65	65.14	23.21	30.21	52.41	17.38	13.04	79.47	7.49	12.24	69.10	18.67	
App/Depart	3098	/	3516	3797	/	2926	4339	/	5314	4993	/	4471	

Peak Hr Begins at: 1130 AM

PEAK

Volumes	35	137	68	115	151	58	41	302	34	57	296	96	1390
Approach %	14.58	57.08	28.33	35.49	46.60	17.90	10.88	80.11	9.02	12.69	65.92	21.38	

PEAK HR.

FACTOR:		0.938		0.900		0.924		0.898		0.944	
---------	--	-------	--	-------	--	-------	--	-------	--	-------	--

CONTROL: 4-Way Stop

COMMENT 1:

GPS: 34.475144, -114.332928

ATTACHMENT C

Trip Generation Analysis

Project: P261048 VICT Tolleson Commerical
Originator: Maria Jimenez
Checked:
Date: 4/23/2026
Data Source: Site Plan, Maricopa County Assessor Map
Reference Manual: ITE Trip Generation Manual, 12th Edition

Size:
Independent Variable:
Time Period: Weekday (Monday - Friday), Peak Hour Adjacent Street Traffic
Setting/Location: General Urban/Suburban

Land Use	LUC	Units	Size	AM Calc			PM Calc			ADT Calc	AM			PM			ADT
				In	Out	Total	In	Out	Total		In	Out	Total	In	Out	Total	
Single-Family Attached Housing	215	Dwelling Units	68.000	25%	75%	0.47	57%	43%	0.51	6.57	8	24	32	20	15	35	447
										Total	8	24	32	20	15	35	447

ATTACHMENT D

Intersection	
Intersection Delay, s/veh	19.3
Intersection LOS	C

Movement	EBL	EBT	EBR	WBL	WBT	WBR	NBL	NBT	NBR	SBL	SBT	SBR
Lane Configurations	🚗	🚗		🚗	🚗		🚗	🚗		🚗	🚗	🚗
Traffic Vol, veh/h	19	137	14	35	265	72	35	191	36	44	178	32
Future Vol, veh/h	19	137	14	35	265	72	35	191	36	44	178	32
Peak Hour Factor	0.92	0.92	0.92	0.92	0.92	0.92	0.92	0.92	0.92	0.92	0.92	0.92
Heavy Vehicles, %	2	2	2	2	2	2	2	2	2	2	2	2
Mvmt Flow	21	149	15	38	288	78	38	208	39	48	193	35
Number of Lanes	1	1	0	1	1	0	1	1	0	1	1	1

Approach	EB	WB	NB	SB
Opposing Approach	WB	EB	SB	NB
Opposing Lanes	2	2	3	2
Conflicting Approach Left	SB	NB	EB	WB
Conflicting Lanes Left	3	2	2	2
Conflicting Approach Right	NB	SB	WB	EB
Conflicting Lanes Right	2	3	2	2
HCM Control Delay, s/veh	14.7	25.8	17.7	14.7
HCM LOS	B	D	C	B

Lane	NBLn1	NBLn2	EBLn1	EBLn2	WBLn1	WBLn2	SBLn1	SBLn2	SBLn3
Vol Left, %	100%	0%	100%	0%	100%	0%	100%	0%	0%
Vol Thru, %	0%	84%	0%	91%	0%	79%	0%	100%	0%
Vol Right, %	0%	16%	0%	9%	0%	21%	0%	0%	100%
Sign Control	Stop	Stop	Stop	Stop	Stop	Stop	Stop	Stop	Stop
Traffic Vol by Lane	35	227	19	151	35	337	44	178	32
LT Vol	35	0	19	0	35	0	44	0	0
Through Vol	0	191	0	137	0	265	0	178	0
RT Vol	0	36	0	14	0	72	0	0	32
Lane Flow Rate	38	247	21	164	38	366	48	193	35
Geometry Grp	6	6	6	6	6	6	6	6	6
Degree of Util (X)	0.087	0.524	0.049	0.361	0.083	0.732	0.11	0.419	0.068
Departure Headway (Hd)	8.267	7.639	8.495	7.917	7.85	7.19	8.314	7.801	7.083
Convergence, Y/N	Yes	Yes	Yes	Yes	Yes	Yes	Yes	Yes	Yes
Cap	432	471	420	453	455	502	429	460	503
Service Time	6.041	5.412	6.276	5.698	5.614	4.954	6.092	5.579	4.86
HCM Lane V/C Ratio	0.088	0.524	0.05	0.362	0.084	0.729	0.112	0.42	0.07
HCM Control Delay, s/veh	11.8	18.6	11.7	15.1	11.3	27.3	12.1	16.1	10.4
HCM Lane LOS	B	C	B	C	B	D	B	C	B
HCM 95th-tile Q	0.3	3	0.2	1.6	0.3	6	0.4	2	0.2

Intersection	
Intersection Delay, s/veh	30.5
Intersection LOS	D

Movement	EBL	EBT	EBR	WBL	WBT	WBR	NBL	NBT	NBR	SBL	SBT	SBR
Lane Configurations	↔	↕		↔	↕		↔	↕		↔	↕	↔
Traffic Vol, veh/h	47	304	25	38	262	76	19	136	56	94	152	49
Future Vol, veh/h	47	304	25	38	262	76	19	136	56	94	152	49
Peak Hour Factor	0.92	0.92	0.92	0.92	0.92	0.92	0.92	0.92	0.92	0.92	0.92	0.92
Heavy Vehicles, %	2	2	2	2	2	2	2	2	2	2	2	2
Mvmt Flow	51	330	27	41	285	83	21	148	61	102	165	53
Number of Lanes	1	1	0	1	1	0	1	1	0	1	1	1

Approach	EB	WB	NB	SB
Opposing Approach	WB	EB	SB	NB
Opposing Lanes	2	2	3	2
Conflicting Approach Left	SB	NB	EB	WB
Conflicting Lanes Left	3	2	2	2
Conflicting Approach Right	NB	SB	WB	EB
Conflicting Lanes Right	2	3	2	2
HCM Control Delay, s/veh	37.8	39.8	20.6	16.3
HCM LOS	E	E	C	C

Lane	NBLn1	NBLn2	EBLn1	EBLn2	WBLn1	WBLn2	SBLn1	SBLn2	SBLn3
Vol Left, %	100%	0%	100%	0%	100%	0%	100%	0%	0%
Vol Thru, %	0%	71%	0%	92%	0%	78%	0%	100%	0%
Vol Right, %	0%	29%	0%	8%	0%	22%	0%	0%	100%
Sign Control	Stop	Stop	Stop	Stop	Stop	Stop	Stop	Stop	Stop
Traffic Vol by Lane	19	192	47	329	38	338	94	152	49
LT Vol	19	0	47	0	38	0	94	0	0
Through Vol	0	136	0	304	0	262	0	152	0
RT Vol	0	56	0	25	0	76	0	0	49
Lane Flow Rate	21	209	51	358	41	367	102	165	53
Geometry Grp	6	6	6	6	6	6	6	6	6
Degree of Util (X)	0.056	0.523	0.127	0.834	0.103	0.847	0.269	0.411	0.122
Departure Headway (Hd)	9.754	9.019	8.967	8.399	8.97	8.295	9.477	8.958	8.232
Convergence, Y/N	Yes	Yes	Yes	Yes	Yes	Yes	Yes	Yes	Yes
Cap	366	399	399	429	399	437	378	401	434
Service Time	7.532	6.796	6.736	6.167	6.737	6.061	7.254	6.734	6.007
HCM Lane V/C Ratio	0.057	0.524	0.128	0.834	0.103	0.84	0.27	0.411	0.122
HCM Control Delay, s/veh	13.1	21.3	13	41.4	12.8	42.8	15.7	17.9	12.2
HCM Lane LOS	B	C	B	E	B	E	C	C	B
HCM 95th-tile Q	0.2	2.9	0.4	7.9	0.3	8.3	1.1	2	0.4

Intersection	
Intersection Delay, s/veh	19.8
Intersection LOS	C

Movement	EBL	EBT	EBR	WBL	WBT	WBR	NBL	NBT	NBR	SBL	SBT	SBR
Lane Configurations	🚗	🚗		🚗	🚗		🚗	🚗		🚗	🚗	🚗
Traffic Vol, veh/h	23	141	15	36	266	72	36	192	37	44	179	33
Future Vol, veh/h	23	141	15	36	266	72	36	192	37	44	179	33
Peak Hour Factor	0.92	0.92	0.92	0.92	0.92	0.92	0.92	0.92	0.92	0.92	0.92	0.92
Heavy Vehicles, %	2	2	2	2	2	2	2	2	2	2	2	2
Mvmt Flow	25	153	16	39	289	78	39	209	40	48	195	36
Number of Lanes	1	1	0	1	1	0	1	1	0	1	1	1

Approach	EB	WB	NB	SB
Opposing Approach	WB	EB	SB	NB
Opposing Lanes	2	2	3	2
Conflicting Approach Left	SB	NB	EB	WB
Conflicting Lanes Left	3	2	2	2
Conflicting Approach Right	NB	SB	WB	EB
Conflicting Lanes Right	2	3	2	2
HCM Control Delay, s/veh	15	26.6	18	14.9
HCM LOS	B	D	C	B

Lane	NBLn1	NBLn2	EBLn1	EBLn2	WBLn1	WBLn2	SBLn1	SBLn2	SBLn3
Vol Left, %	100%	0%	100%	0%	100%	0%	100%	0%	0%
Vol Thru, %	0%	84%	0%	90%	0%	79%	0%	100%	0%
Vol Right, %	0%	16%	0%	10%	0%	21%	0%	0%	100%
Sign Control	Stop	Stop	Stop	Stop	Stop	Stop	Stop	Stop	Stop
Traffic Vol by Lane	36	229	23	156	36	338	44	179	33
LT Vol	36	0	23	0	36	0	44	0	0
Through Vol	0	192	0	141	0	266	0	179	0
RT Vol	0	37	0	15	0	72	0	0	33
Lane Flow Rate	39	249	25	170	39	367	48	195	36
Geometry Grp	6	6	6	6	6	6	6	6	6
Degree of Util (X)	0.091	0.533	0.059	0.375	0.086	0.741	0.112	0.426	0.071
Departure Headway (Hd)	8.339	7.708	8.55	7.969	7.922	7.262	8.393	7.88	7.161
Convergence, Y/N	Yes	Yes	Yes	Yes	Yes	Yes	Yes	Yes	Yes
Cap	428	465	417	449	451	496	426	455	498
Service Time	6.12	5.489	6.337	5.756	5.692	5.032	6.175	5.661	4.942
HCM Lane V/C Ratio	0.091	0.535	0.06	0.379	0.086	0.74	0.113	0.429	0.072
HCM Control Delay, s/veh	12	19	11.9	15.5	11.4	28.2	12.2	16.4	10.5
HCM Lane LOS	B	C	B	C	B	D	B	C	B
HCM 95th-tile Q	0.3	3.1	0.2	1.7	0.3	6.2	0.4	2.1	0.2

Intersection	
Intersection Delay, s/veh	31.4
Intersection LOS	D

Movement	EBL	EBT	EBR	WBL	WBT	WBR	NBL	NBT	NBR	SBL	SBT	SBR
Lane Configurations	🚗	🚗		🚗	🚗		🚗	🚗		🚗	🚗	🚗
Traffic Vol, veh/h	49	306	25	40	264	74	21	137	57	94	154	51
Future Vol, veh/h	49	306	25	40	264	74	21	137	57	94	154	51
Peak Hour Factor	0.92	0.92	0.92	0.92	0.92	0.92	0.92	0.92	0.92	0.92	0.92	0.92
Heavy Vehicles, %	2	2	2	2	2	2	2	2	2	2	2	2
Mvmt Flow	53	333	27	43	287	80	23	149	62	102	167	55
Number of Lanes	1	1	0	1	1	0	1	1	0	1	1	1

Approach	EB	WB	NB	SB
Opposing Approach	WB	EB	SB	NB
Opposing Lanes	2	2	3	2
Conflicting Approach Left	SB	NB	EB	WB
Conflicting Lanes Left	3	2	2	2
Conflicting Approach Right	NB	SB	WB	EB
Conflicting Lanes Right	2	3	2	2
HCM Control Delay, s/veh	39.4	40.9	21	16.5
HCM LOS	E	E	C	C

Lane	NBLn1	NBLn2	EBLn1	EBLn2	WBLn1	WBLn2	SBLn1	SBLn2	SBLn3
Vol Left, %	100%	0%	100%	0%	100%	0%	100%	0%	0%
Vol Thru, %	0%	71%	0%	92%	0%	78%	0%	100%	0%
Vol Right, %	0%	29%	0%	8%	0%	22%	0%	0%	100%
Sign Control	Stop	Stop	Stop	Stop	Stop	Stop	Stop	Stop	Stop
Traffic Vol by Lane	21	194	49	331	40	338	94	154	51
LT Vol	21	0	49	0	40	0	94	0	0
Through Vol	0	137	0	306	0	264	0	154	0
RT Vol	0	57	0	25	0	74	0	0	51
Lane Flow Rate	23	211	53	360	43	367	102	167	55
Geometry Grp	6	6	6	6	6	6	6	6	6
Degree of Util (X)	0.062	0.532	0.134	0.846	0.109	0.855	0.271	0.42	0.128
Departure Headway (Hd)	9.826	9.089	9.037	8.469	9.047	8.375	9.554	9.035	8.308
Convergence, Y/N	Yes	Yes	Yes	Yes	Yes	Yes	Yes	Yes	Yes
Cap	364	396	396	428	396	434	375	398	430
Service Time	7.606	6.868	6.807	6.239	6.816	6.144	7.328	6.808	6.081
HCM Lane V/C Ratio	0.063	0.533	0.134	0.841	0.109	0.846	0.272	0.42	0.128
HCM Control Delay, s/veh	13.3	21.8	13.2	43.3	12.9	44.2	15.9	18.2	12.3
HCM Lane LOS	B	C	B	E	B	E	C	C	B
HCM 95th-tile Q	0.2	3	0.5	8.2	0.4	8.4	1.1	2	0.4

ATTACHMENT E

Warrants Summary Report

1: Swanson Ave & Smoketree Ave

Intersection Information:

	Major Street	Minor Street
Street Name	Swanson Ave	Smoketree Ave
Direction	EB/WB	NB/SB
Number of Lanes	2	2
Approach Speed	30	35

Warrant	Met?	Notes
Warrant 1, Eight-Hour Vehicular Volume		
	Yes	
Condition A or B Met?	Yes	9 Hours met (8 required)
Condition A and B Met?	Yes	8 Hours met (8 required)
Warrant 2, Four-Hour Vehicular Volume		
	Yes	5 Hours met (4 required)
Warrant 7, Crash Experience		
	No	
Traffic Volume Cond.?	Yes	11 Hours met (8 required)
Ped Condition?	No	0 Hours met (8 required)

Warrant 1: Eight-hour Vehicular Volume

1: Swanson Ave & Smoketree Ave

Intersection Information:

Major Street Name: Swanson Ave
 Major Street Direction: EB/WB
 Minor Street Direction: NB/SB

WARRANT 1 MET? Yes

Details:

Condition A Met? **Yes** 9 Hours met (8 required) at 100%
 Condition B Met? **No** 0 Hours met (8 required) at 100%

Hour	Major Street Vehicles (Total of Both Approaches)	High Volume Minor Approach Vehicles	100% Standard Met? Cond. A OR Cond. B		80% Standard Met? Cond. A AND Cond. B	
			Condition A 100% Column	Condition B 100% Column	Condition A 80% Column	Condition B 80% Column
00:00 to 01:00	18	8	No	No	No	No
Condition A	Volume >= 100% column (600)?	No	Volume >= 100% column (200)?	No		
	Volume >= 80% column (480)?	No	Volume >= 80% column (160)?	No		
Condition B	Volume >= 100% column (900)?	No	Volume >= 100% column (100)?	No		
	Volume >= 80% column (720)?	No	Volume >= 80% column (80)?	No		
00:15 to 01:15	19	6	No	No	No	No
Condition A	Volume >= 100% column (600)?	No	Volume >= 100% column (200)?	No		
	Volume >= 80% column (480)?	No	Volume >= 80% column (160)?	No		
Condition B	Volume >= 100% column (900)?	No	Volume >= 100% column (100)?	No		
	Volume >= 80% column (720)?	No	Volume >= 80% column (80)?	No		
00:30 to 01:30	16	5	No	No	No	No
Condition A	Volume >= 100% column (600)?	No	Volume >= 100% column (200)?	No		
	Volume >= 80% column (480)?	No	Volume >= 80% column (160)?	No		
Condition B	Volume >= 100% column (900)?	No	Volume >= 100% column (100)?	No		
	Volume >= 80% column (720)?	No	Volume >= 80% column (80)?	No		
00:45 to 01:45	16	4	No	No	No	No
Condition A	Volume >= 100% column (600)?	No	Volume >= 100% column (200)?	No		
	Volume >= 80% column (480)?	No	Volume >= 80% column (160)?	No		
Condition B	Volume >= 100% column (900)?	No	Volume >= 100% column (100)?	No		
	Volume >= 80% column (720)?	No	Volume >= 80% column (80)?	No		

01:00 to 02:00	15	5	No	No	No	No
Condition A	Volume >= 100% column (600)?	No	Volume >= 100% column (200)?	No		
	Volume >= 80% column (480)?	No	Volume >= 80% column (160)?	No		
Condition B	Volume >= 100% column (900)?	No	Volume >= 100% column (100)?	No		
	Volume >= 80% column (720)?	No	Volume >= 80% column (80)?	No		

01:15 to 02:15	18	4	No	No	No	No
Condition A	Volume >= 100% column (600)?	No	Volume >= 100% column (200)?	No		
	Volume >= 80% column (480)?	No	Volume >= 80% column (160)?	No		
Condition B	Volume >= 100% column (900)?	No	Volume >= 100% column (100)?	No		
	Volume >= 80% column (720)?	No	Volume >= 80% column (80)?	No		

01:30 to 02:30	20	3	No	No	No	No
Condition A	Volume >= 100% column (600)?	No	Volume >= 100% column (200)?	No		
	Volume >= 80% column (480)?	No	Volume >= 80% column (160)?	No		
Condition B	Volume >= 100% column (900)?	No	Volume >= 100% column (100)?	No		
	Volume >= 80% column (720)?	No	Volume >= 80% column (80)?	No		

01:45 to 02:45	20	2	No	No	No	No
Condition A	Volume >= 100% column (600)?	No	Volume >= 100% column (200)?	No		
	Volume >= 80% column (480)?	No	Volume >= 80% column (160)?	No		
Condition B	Volume >= 100% column (900)?	No	Volume >= 100% column (100)?	No		
	Volume >= 80% column (720)?	No	Volume >= 80% column (80)?	No		

02:00 to 03:00	22	3	No	No	No	No
Condition A	Volume >= 100% column (600)?	No	Volume >= 100% column (200)?	No		
	Volume >= 80% column (480)?	No	Volume >= 80% column (160)?	No		
Condition B	Volume >= 100% column (900)?	No	Volume >= 100% column (100)?	No		
	Volume >= 80% column (720)?	No	Volume >= 80% column (80)?	No		

02:15 to 03:15	14	3	No	No	No	No
Condition A	Volume >= 100% column (600)?	No	Volume >= 100% column (200)?	No		
	Volume >= 80% column (480)?	No	Volume >= 80% column (160)?	No		
Condition B	Volume >= 100% column (900)?	No	Volume >= 100% column (100)?	No		
	Volume >= 80% column (720)?	No	Volume >= 80% column (80)?	No		

02:30 to 03:30		10		6		No	No	No	No
Condition A	Volume >= 100% column (600)?	No	Volume >= 100% column (200)?	No					
	Volume >= 80% column (480)?	No	Volume >= 80% column (160)?	No					
Condition B	Volume >= 100% column (900)?	No	Volume >= 100% column (100)?	No					
	Volume >= 80% column (720)?	No	Volume >= 80% column (80)?	No					

02:45 to 03:45		11		5		No	No	No	No
Condition A	Volume >= 100% column (600)?	No	Volume >= 100% column (200)?	No					
	Volume >= 80% column (480)?	No	Volume >= 80% column (160)?	No					
Condition B	Volume >= 100% column (900)?	No	Volume >= 100% column (100)?	No					
	Volume >= 80% column (720)?	No	Volume >= 80% column (80)?	No					

03:00 to 04:00		12		4		No	No	No	No
Condition A	Volume >= 100% column (600)?	No	Volume >= 100% column (200)?	No					
	Volume >= 80% column (480)?	No	Volume >= 80% column (160)?	No					
Condition B	Volume >= 100% column (900)?	No	Volume >= 100% column (100)?	No					
	Volume >= 80% column (720)?	No	Volume >= 80% column (80)?	No					

03:15 to 04:15		16		7		No	No	No	No
Condition A	Volume >= 100% column (600)?	No	Volume >= 100% column (200)?	No					
	Volume >= 80% column (480)?	No	Volume >= 80% column (160)?	No					
Condition B	Volume >= 100% column (900)?	No	Volume >= 100% column (100)?	No					
	Volume >= 80% column (720)?	No	Volume >= 80% column (80)?	No					

03:30 to 04:30		26		10		No	No	No	No
Condition A	Volume >= 100% column (600)?	No	Volume >= 100% column (200)?	No					
	Volume >= 80% column (480)?	No	Volume >= 80% column (160)?	No					
Condition B	Volume >= 100% column (900)?	No	Volume >= 100% column (100)?	No					
	Volume >= 80% column (720)?	No	Volume >= 80% column (80)?	No					

03:45 to 04:45		31		12		No	No	No	No
Condition A	Volume >= 100% column (600)?	No	Volume >= 100% column (200)?	No					
	Volume >= 80% column (480)?	No	Volume >= 80% column (160)?	No					
Condition B	Volume >= 100% column (900)?	No	Volume >= 100% column (100)?	No					
	Volume >= 80% column (720)?	No	Volume >= 80% column (80)?	No					

04:00 to 05:00		49		19		No	No	No	No
Condition A	Volume >= 100% column (600)?	No	Volume >= 100% column (200)?	No					
	Volume >= 80% column (480)?	No	Volume >= 80% column (160)?	No					
Condition B	Volume >= 100% column (900)?	No	Volume >= 100% column (100)?	No					
	Volume >= 80% column (720)?	No	Volume >= 80% column (80)?	No					

04:15 to 05:15		60		26		No	No	No	No
Condition A	Volume >= 100% column (600)?	No	Volume >= 100% column (200)?	No					
	Volume >= 80% column (480)?	No	Volume >= 80% column (160)?	No					
Condition B	Volume >= 100% column (900)?	No	Volume >= 100% column (100)?	No					
	Volume >= 80% column (720)?	No	Volume >= 80% column (80)?	No					

04:30 to 05:30		70		38		No	No	No	No
Condition A	Volume >= 100% column (600)?	No	Volume >= 100% column (200)?	No					
	Volume >= 80% column (480)?	No	Volume >= 80% column (160)?	No					
Condition B	Volume >= 100% column (900)?	No	Volume >= 100% column (100)?	No					
	Volume >= 80% column (720)?	No	Volume >= 80% column (80)?	No					

04:45 to 05:45		80		53		No	No	No	No
Condition A	Volume >= 100% column (600)?	No	Volume >= 100% column (200)?	No					
	Volume >= 80% column (480)?	No	Volume >= 80% column (160)?	No					
Condition B	Volume >= 100% column (900)?	No	Volume >= 100% column (100)?	No					
	Volume >= 80% column (720)?	No	Volume >= 80% column (80)?	No					

05:00 to 06:00		99		65		No	No	No	No
Condition A	Volume >= 100% column (600)?	No	Volume >= 100% column (200)?	No					
	Volume >= 80% column (480)?	No	Volume >= 80% column (160)?	No					
Condition B	Volume >= 100% column (900)?	No	Volume >= 100% column (100)?	No					
	Volume >= 80% column (720)?	No	Volume >= 80% column (80)?	No					

05:15 to 06:15		126		77		No	No	No	No
Condition A	Volume >= 100% column (600)?	No	Volume >= 100% column (200)?	No					
	Volume >= 80% column (480)?	No	Volume >= 80% column (160)?	No					
Condition B	Volume >= 100% column (900)?	No	Volume >= 100% column (100)?	No					
	Volume >= 80% column (720)?	No	Volume >= 80% column (80)?	No					

05:30 to 06:30	149	77	No	No	No	No
Condition A	Volume >= 100% column (600)?	No	Volume >= 100% column (200)?	No		
	Volume >= 80% column (480)?	No	Volume >= 80% column (160)?	No		
Condition B	Volume >= 100% column (900)?	No	Volume >= 100% column (100)?	No		
	Volume >= 80% column (720)?	No	Volume >= 80% column (80)?	No		

05:45 to 06:45	185	76	No	No	No	No
Condition A	Volume >= 100% column (600)?	No	Volume >= 100% column (200)?	No		
	Volume >= 80% column (480)?	No	Volume >= 80% column (160)?	No		
Condition B	Volume >= 100% column (900)?	No	Volume >= 100% column (100)?	No		
	Volume >= 80% column (720)?	No	Volume >= 80% column (80)?	No		

06:00 to 07:00	202	83	No	No	No	No
Condition A	Volume >= 100% column (600)?	No	Volume >= 100% column (200)?	No		
	Volume >= 80% column (480)?	No	Volume >= 80% column (160)?	No		
Condition B	Volume >= 100% column (900)?	No	Volume >= 100% column (100)?	No		
	Volume >= 80% column (720)?	No	Volume >= 80% column (80)?	Yes		

06:15 to 07:15	219	90	No	No	No	No
Condition A	Volume >= 100% column (600)?	No	Volume >= 100% column (200)?	No		
	Volume >= 80% column (480)?	No	Volume >= 80% column (160)?	No		
Condition B	Volume >= 100% column (900)?	No	Volume >= 100% column (100)?	No		
	Volume >= 80% column (720)?	No	Volume >= 80% column (80)?	Yes		

06:30 to 07:30	267	119	No	No	No	No
Condition A	Volume >= 100% column (600)?	No	Volume >= 100% column (200)?	No		
	Volume >= 80% column (480)?	No	Volume >= 80% column (160)?	No		
Condition B	Volume >= 100% column (900)?	No	Volume >= 100% column (100)?	Yes		
	Volume >= 80% column (720)?	No	Volume >= 80% column (80)?	Yes		

06:45 to 07:45	311	169	No	No	No	No
Condition A	Volume >= 100% column (600)?	No	Volume >= 100% column (200)?	No		
	Volume >= 80% column (480)?	No	Volume >= 80% column (160)?	Yes		
Condition B	Volume >= 100% column (900)?	No	Volume >= 100% column (100)?	Yes		
	Volume >= 80% column (720)?	No	Volume >= 80% column (80)?	Yes		

07:00 to 08:00	429	220	No	No	No	No
Condition A	Volume >= 100% column (600)?	No	Volume >= 100% column (200)?	Yes		
	Volume >= 80% column (480)?	No	Volume >= 80% column (160)?	Yes		
Condition B	Volume >= 100% column (900)?	No	Volume >= 100% column (100)?	Yes		
	Volume >= 80% column (720)?	No	Volume >= 80% column (80)?	Yes		

07:15 to 08:15	511	247	No	No	Yes	No
Condition A	Volume >= 100% column (600)?	No	Volume >= 100% column (200)?	Yes		
	Volume >= 80% column (480)?	Yes	Volume >= 80% column (160)?	Yes		
Condition B	Volume >= 100% column (900)?	No	Volume >= 100% column (100)?	Yes		
	Volume >= 80% column (720)?	No	Volume >= 80% column (80)?	Yes		

07:30 to 08:30	526	254	No	No	Yes	No
Condition A	Volume >= 100% column (600)?	No	Volume >= 100% column (200)?	Yes		
	Volume >= 80% column (480)?	Yes	Volume >= 80% column (160)?	Yes		
Condition B	Volume >= 100% column (900)?	No	Volume >= 100% column (100)?	Yes		
	Volume >= 80% column (720)?	No	Volume >= 80% column (80)?	Yes		

07:45 to 08:45	544	247	No	No	Yes	No
Condition A	Volume >= 100% column (600)?	No	Volume >= 100% column (200)?	Yes		
	Volume >= 80% column (480)?	Yes	Volume >= 80% column (160)?	Yes		
Condition B	Volume >= 100% column (900)?	No	Volume >= 100% column (100)?	Yes		
	Volume >= 80% column (720)?	No	Volume >= 80% column (80)?	Yes		

08:00 to 09:00	524	233	No	No	Yes	No
Condition A	Volume >= 100% column (600)?	No	Volume >= 100% column (200)?	Yes		
	Volume >= 80% column (480)?	Yes	Volume >= 80% column (160)?	Yes		
Condition B	Volume >= 100% column (900)?	No	Volume >= 100% column (100)?	Yes		
	Volume >= 80% column (720)?	No	Volume >= 80% column (80)?	Yes		

08:15 to 09:15	540	226	No	No	Yes	No
Condition A	Volume >= 100% column (600)?	No	Volume >= 100% column (200)?	Yes		
	Volume >= 80% column (480)?	Yes	Volume >= 80% column (160)?	Yes		
Condition B	Volume >= 100% column (900)?	No	Volume >= 100% column (100)?	Yes		
	Volume >= 80% column (720)?	No	Volume >= 80% column (80)?	Yes		

08:30 to 09:30		610		236		Yes*	No	Yes	No
Condition A	Volume >= 100% column (600)?	Yes	Volume >= 100% column (200)?	Yes					
	Volume >= 80% column (480)?	Yes	Volume >= 80% column (160)?	Yes					
Condition B	Volume >= 100% column (900)?	No	Volume >= 100% column (100)?	Yes					
	Volume >= 80% column (720)?	No	Volume >= 80% column (80)?	Yes					

08:45 to 09:45		657		245		Yes	No	Yes	No
Condition A	Volume >= 100% column (600)?	Yes	Volume >= 100% column (200)?	Yes					
	Volume >= 80% column (480)?	Yes	Volume >= 80% column (160)?	Yes					
Condition B	Volume >= 100% column (900)?	No	Volume >= 100% column (100)?	Yes					
	Volume >= 80% column (720)?	No	Volume >= 80% column (80)?	Yes					

09:00 to 10:00		697		271		Yes	No	Yes	No
Condition A	Volume >= 100% column (600)?	Yes	Volume >= 100% column (200)?	Yes					
	Volume >= 80% column (480)?	Yes	Volume >= 80% column (160)?	Yes					
Condition B	Volume >= 100% column (900)?	No	Volume >= 100% column (100)?	Yes					
	Volume >= 80% column (720)?	No	Volume >= 80% column (80)?	Yes					

09:15 to 10:15		721		287		Yes	No	Yes*	Yes*
Condition A	Volume >= 100% column (600)?	Yes	Volume >= 100% column (200)?	Yes					
	Volume >= 80% column (480)?	Yes	Volume >= 80% column (160)?	Yes					
Condition B	Volume >= 100% column (900)?	No	Volume >= 100% column (100)?	Yes					
	Volume >= 80% column (720)?	Yes	Volume >= 80% column (80)?	Yes					

09:30 to 10:30		725		294		Yes*	No	Yes	Yes
Condition A	Volume >= 100% column (600)?	Yes	Volume >= 100% column (200)?	Yes					
	Volume >= 80% column (480)?	Yes	Volume >= 80% column (160)?	Yes					
Condition B	Volume >= 100% column (900)?	No	Volume >= 100% column (100)?	Yes					
	Volume >= 80% column (720)?	Yes	Volume >= 80% column (80)?	Yes					

09:45 to 10:45		741		291		Yes	No	Yes	Yes
Condition A	Volume >= 100% column (600)?	Yes	Volume >= 100% column (200)?	Yes					
	Volume >= 80% column (480)?	Yes	Volume >= 80% column (160)?	Yes					
Condition B	Volume >= 100% column (900)?	No	Volume >= 100% column (100)?	Yes					
	Volume >= 80% column (720)?	Yes	Volume >= 80% column (80)?	Yes					

10:00 to 11:00	744	290	Yes	No	Yes	Yes
Condition A	Volume >= 100% column (600)?	Yes	Volume >= 100% column (200)?	Yes		
	Volume >= 80% column (480)?	Yes	Volume >= 80% column (160)?	Yes		
Condition B	Volume >= 100% column (900)?	No	Volume >= 100% column (100)?	Yes		
	Volume >= 80% column (720)?	Yes	Volume >= 80% column (80)?	Yes		

10:15 to 11:15	728	307	Yes	No	Yes*	Yes*
Condition A	Volume >= 100% column (600)?	Yes	Volume >= 100% column (200)?	Yes		
	Volume >= 80% column (480)?	Yes	Volume >= 80% column (160)?	Yes		
Condition B	Volume >= 100% column (900)?	No	Volume >= 100% column (100)?	Yes		
	Volume >= 80% column (720)?	Yes	Volume >= 80% column (80)?	Yes		

10:30 to 11:30	735	301	Yes*	No	Yes	Yes
Condition A	Volume >= 100% column (600)?	Yes	Volume >= 100% column (200)?	Yes		
	Volume >= 80% column (480)?	Yes	Volume >= 80% column (160)?	Yes		
Condition B	Volume >= 100% column (900)?	No	Volume >= 100% column (100)?	Yes		
	Volume >= 80% column (720)?	Yes	Volume >= 80% column (80)?	Yes		

10:45 to 11:45	760	324	Yes	No	Yes	Yes
Condition A	Volume >= 100% column (600)?	Yes	Volume >= 100% column (200)?	Yes		
	Volume >= 80% column (480)?	Yes	Volume >= 80% column (160)?	Yes		
Condition B	Volume >= 100% column (900)?	No	Volume >= 100% column (100)?	Yes		
	Volume >= 80% column (720)?	Yes	Volume >= 80% column (80)?	Yes		

11:00 to 12:00	771	320	Yes	No	Yes	Yes
Condition A	Volume >= 100% column (600)?	Yes	Volume >= 100% column (200)?	Yes		
	Volume >= 80% column (480)?	Yes	Volume >= 80% column (160)?	Yes		
Condition B	Volume >= 100% column (900)?	No	Volume >= 100% column (100)?	Yes		
	Volume >= 80% column (720)?	Yes	Volume >= 80% column (80)?	Yes		

11:15 to 12:15	832	314	Yes	No	Yes*	Yes*
Condition A	Volume >= 100% column (600)?	Yes	Volume >= 100% column (200)?	Yes		
	Volume >= 80% column (480)?	Yes	Volume >= 80% column (160)?	Yes		
Condition B	Volume >= 100% column (900)?	No	Volume >= 100% column (100)?	Yes		
	Volume >= 80% column (720)?	Yes	Volume >= 80% column (80)?	Yes		

11:30 to 12:30	826	324	Yes*	No	Yes	Yes
Condition A	Volume >= 100% column (600)?	Yes	Volume >= 100% column (200)?	Yes		
	Volume >= 80% column (480)?	Yes	Volume >= 80% column (160)?	Yes		
Condition B	Volume >= 100% column (900)?	No	Volume >= 100% column (100)?	Yes		
	Volume >= 80% column (720)?	Yes	Volume >= 80% column (80)?	Yes		

11:45 to 12:45	816	298	Yes	No	Yes	Yes
Condition A	Volume >= 100% column (600)?	Yes	Volume >= 100% column (200)?	Yes		
	Volume >= 80% column (480)?	Yes	Volume >= 80% column (160)?	Yes		
Condition B	Volume >= 100% column (900)?	No	Volume >= 100% column (100)?	Yes		
	Volume >= 80% column (720)?	Yes	Volume >= 80% column (80)?	Yes		

12:00 to 13:00	798	295	Yes	No	Yes	Yes
Condition A	Volume >= 100% column (600)?	Yes	Volume >= 100% column (200)?	Yes		
	Volume >= 80% column (480)?	Yes	Volume >= 80% column (160)?	Yes		
Condition B	Volume >= 100% column (900)?	No	Volume >= 100% column (100)?	Yes		
	Volume >= 80% column (720)?	Yes	Volume >= 80% column (80)?	Yes		

12:15 to 13:15	777	300	Yes	No	Yes*	Yes*
Condition A	Volume >= 100% column (600)?	Yes	Volume >= 100% column (200)?	Yes		
	Volume >= 80% column (480)?	Yes	Volume >= 80% column (160)?	Yes		
Condition B	Volume >= 100% column (900)?	No	Volume >= 100% column (100)?	Yes		
	Volume >= 80% column (720)?	Yes	Volume >= 80% column (80)?	Yes		

12:30 to 13:30	778	290	Yes*	No	Yes	Yes
Condition A	Volume >= 100% column (600)?	Yes	Volume >= 100% column (200)?	Yes		
	Volume >= 80% column (480)?	Yes	Volume >= 80% column (160)?	Yes		
Condition B	Volume >= 100% column (900)?	No	Volume >= 100% column (100)?	Yes		
	Volume >= 80% column (720)?	Yes	Volume >= 80% column (80)?	Yes		

12:45 to 13:45	758	297	Yes	No	Yes	Yes
Condition A	Volume >= 100% column (600)?	Yes	Volume >= 100% column (200)?	Yes		
	Volume >= 80% column (480)?	Yes	Volume >= 80% column (160)?	Yes		
Condition B	Volume >= 100% column (900)?	No	Volume >= 100% column (100)?	Yes		
	Volume >= 80% column (720)?	Yes	Volume >= 80% column (80)?	Yes		

13:00 to 14:00		800	297		Yes	No	Yes	Yes
Condition A	Volume >= 100% column (600)?	Yes	Volume >= 100% column (200)?	Yes				
	Volume >= 80% column (480)?	Yes	Volume >= 80% column (160)?	Yes				
Condition B	Volume >= 100% column (900)?	No	Volume >= 100% column (100)?	Yes				
	Volume >= 80% column (720)?	Yes	Volume >= 80% column (80)?	Yes				

13:15 to 14:15		797	286		Yes	No	Yes*	Yes*
Condition A	Volume >= 100% column (600)?	Yes	Volume >= 100% column (200)?	Yes				
	Volume >= 80% column (480)?	Yes	Volume >= 80% column (160)?	Yes				
Condition B	Volume >= 100% column (900)?	No	Volume >= 100% column (100)?	Yes				
	Volume >= 80% column (720)?	Yes	Volume >= 80% column (80)?	Yes				

13:30 to 14:30		825	292		Yes*	No	Yes	Yes
Condition A	Volume >= 100% column (600)?	Yes	Volume >= 100% column (200)?	Yes				
	Volume >= 80% column (480)?	Yes	Volume >= 80% column (160)?	Yes				
Condition B	Volume >= 100% column (900)?	No	Volume >= 100% column (100)?	Yes				
	Volume >= 80% column (720)?	Yes	Volume >= 80% column (80)?	Yes				

13:45 to 14:45		819	312		Yes	No	Yes	Yes
Condition A	Volume >= 100% column (600)?	Yes	Volume >= 100% column (200)?	Yes				
	Volume >= 80% column (480)?	Yes	Volume >= 80% column (160)?	Yes				
Condition B	Volume >= 100% column (900)?	No	Volume >= 100% column (100)?	Yes				
	Volume >= 80% column (720)?	Yes	Volume >= 80% column (80)?	Yes				

14:00 to 15:00		782	337		Yes	No	Yes	Yes
Condition A	Volume >= 100% column (600)?	Yes	Volume >= 100% column (200)?	Yes				
	Volume >= 80% column (480)?	Yes	Volume >= 80% column (160)?	Yes				
Condition B	Volume >= 100% column (900)?	No	Volume >= 100% column (100)?	Yes				
	Volume >= 80% column (720)?	Yes	Volume >= 80% column (80)?	Yes				

14:15 to 15:15		791	351		Yes	No	Yes*	Yes*
Condition A	Volume >= 100% column (600)?	Yes	Volume >= 100% column (200)?	Yes				
	Volume >= 80% column (480)?	Yes	Volume >= 80% column (160)?	Yes				
Condition B	Volume >= 100% column (900)?	No	Volume >= 100% column (100)?	Yes				
	Volume >= 80% column (720)?	Yes	Volume >= 80% column (80)?	Yes				

14:30 to 15:30	764	356	Yes*	No	Yes	Yes
Condition A	Volume >= 100% column (600)?	Yes	Volume >= 100% column (200)?	Yes		
	Volume >= 80% column (480)?	Yes	Volume >= 80% column (160)?	Yes		
Condition B	Volume >= 100% column (900)?	No	Volume >= 100% column (100)?	Yes		
	Volume >= 80% column (720)?	Yes	Volume >= 80% column (80)?	Yes		

14:45 to 15:45	778	335	Yes	No	Yes	Yes
Condition A	Volume >= 100% column (600)?	Yes	Volume >= 100% column (200)?	Yes		
	Volume >= 80% column (480)?	Yes	Volume >= 80% column (160)?	Yes		
Condition B	Volume >= 100% column (900)?	No	Volume >= 100% column (100)?	Yes		
	Volume >= 80% column (720)?	Yes	Volume >= 80% column (80)?	Yes		

15:00 to 16:00	753	316	Yes	No	Yes	Yes
Condition A	Volume >= 100% column (600)?	Yes	Volume >= 100% column (200)?	Yes		
	Volume >= 80% column (480)?	Yes	Volume >= 80% column (160)?	Yes		
Condition B	Volume >= 100% column (900)?	No	Volume >= 100% column (100)?	Yes		
	Volume >= 80% column (720)?	Yes	Volume >= 80% column (80)?	Yes		

15:15 to 16:15	724	299	Yes	No	Yes*	Yes*
Condition A	Volume >= 100% column (600)?	Yes	Volume >= 100% column (200)?	Yes		
	Volume >= 80% column (480)?	Yes	Volume >= 80% column (160)?	Yes		
Condition B	Volume >= 100% column (900)?	No	Volume >= 100% column (100)?	Yes		
	Volume >= 80% column (720)?	Yes	Volume >= 80% column (80)?	Yes		

15:30 to 16:30	722	286	Yes*	No	Yes	Yes
Condition A	Volume >= 100% column (600)?	Yes	Volume >= 100% column (200)?	Yes		
	Volume >= 80% column (480)?	Yes	Volume >= 80% column (160)?	Yes		
Condition B	Volume >= 100% column (900)?	No	Volume >= 100% column (100)?	Yes		
	Volume >= 80% column (720)?	Yes	Volume >= 80% column (80)?	Yes		

15:45 to 16:45	721	283	Yes	No	Yes	Yes
Condition A	Volume >= 100% column (600)?	Yes	Volume >= 100% column (200)?	Yes		
	Volume >= 80% column (480)?	Yes	Volume >= 80% column (160)?	Yes		
Condition B	Volume >= 100% column (900)?	No	Volume >= 100% column (100)?	Yes		
	Volume >= 80% column (720)?	Yes	Volume >= 80% column (80)?	Yes		

16:00 to 17:00		705	275		Yes	No	Yes	No
Condition A	Volume >= 100% column (600)?	Yes	Volume >= 100% column (200)?	Yes				
	Volume >= 80% column (480)?	Yes	Volume >= 80% column (160)?	Yes				
Condition B	Volume >= 100% column (900)?	No	Volume >= 100% column (100)?	Yes				
	Volume >= 80% column (720)?	No	Volume >= 80% column (80)?	Yes				

16:15 to 17:15		728	287		Yes	No	Yes*	Yes*
Condition A	Volume >= 100% column (600)?	Yes	Volume >= 100% column (200)?	Yes				
	Volume >= 80% column (480)?	Yes	Volume >= 80% column (160)?	Yes				
Condition B	Volume >= 100% column (900)?	No	Volume >= 100% column (100)?	Yes				
	Volume >= 80% column (720)?	Yes	Volume >= 80% column (80)?	Yes				

16:30 to 17:30		693	295		Yes*	No	Yes	No
Condition A	Volume >= 100% column (600)?	Yes	Volume >= 100% column (200)?	Yes				
	Volume >= 80% column (480)?	Yes	Volume >= 80% column (160)?	Yes				
Condition B	Volume >= 100% column (900)?	No	Volume >= 100% column (100)?	Yes				
	Volume >= 80% column (720)?	No	Volume >= 80% column (80)?	Yes				

16:45 to 17:45		666	283		Yes	No	Yes	No
Condition A	Volume >= 100% column (600)?	Yes	Volume >= 100% column (200)?	Yes				
	Volume >= 80% column (480)?	Yes	Volume >= 80% column (160)?	Yes				
Condition B	Volume >= 100% column (900)?	No	Volume >= 100% column (100)?	Yes				
	Volume >= 80% column (720)?	No	Volume >= 80% column (80)?	Yes				

17:00 to 18:00		647	288		Yes	No	Yes	No
Condition A	Volume >= 100% column (600)?	Yes	Volume >= 100% column (200)?	Yes				
	Volume >= 80% column (480)?	Yes	Volume >= 80% column (160)?	Yes				
Condition B	Volume >= 100% column (900)?	No	Volume >= 100% column (100)?	Yes				
	Volume >= 80% column (720)?	No	Volume >= 80% column (80)?	Yes				

17:15 to 18:15		566	273		No	No	Yes	No
Condition A	Volume >= 100% column (600)?	No	Volume >= 100% column (200)?	Yes				
	Volume >= 80% column (480)?	Yes	Volume >= 80% column (160)?	Yes				
Condition B	Volume >= 100% column (900)?	No	Volume >= 100% column (100)?	Yes				
	Volume >= 80% column (720)?	No	Volume >= 80% column (80)?	Yes				

17:30 to 18:30	534	228	No	No	Yes	No
Condition A	Volume >= 100% column (600)?	No	Volume >= 100% column (200)?	Yes		
	Volume >= 80% column (480)?	Yes	Volume >= 80% column (160)?	Yes		
Condition B	Volume >= 100% column (900)?	No	Volume >= 100% column (100)?	Yes		
	Volume >= 80% column (720)?	No	Volume >= 80% column (80)?	Yes		

17:45 to 18:45	476	215	No	No	No	No
Condition A	Volume >= 100% column (600)?	No	Volume >= 100% column (200)?	Yes		
	Volume >= 80% column (480)?	No	Volume >= 80% column (160)?	Yes		
Condition B	Volume >= 100% column (900)?	No	Volume >= 100% column (100)?	Yes		
	Volume >= 80% column (720)?	No	Volume >= 80% column (80)?	Yes		

18:00 to 19:00	461	179	No	No	No	No
Condition A	Volume >= 100% column (600)?	No	Volume >= 100% column (200)?	No		
	Volume >= 80% column (480)?	No	Volume >= 80% column (160)?	Yes		
Condition B	Volume >= 100% column (900)?	No	Volume >= 100% column (100)?	Yes		
	Volume >= 80% column (720)?	No	Volume >= 80% column (80)?	Yes		

18:15 to 19:15	439	165	No	No	No	No
Condition A	Volume >= 100% column (600)?	No	Volume >= 100% column (200)?	No		
	Volume >= 80% column (480)?	No	Volume >= 80% column (160)?	Yes		
Condition B	Volume >= 100% column (900)?	No	Volume >= 100% column (100)?	Yes		
	Volume >= 80% column (720)?	No	Volume >= 80% column (80)?	Yes		

18:30 to 19:30	401	156	No	No	No	No
Condition A	Volume >= 100% column (600)?	No	Volume >= 100% column (200)?	No		
	Volume >= 80% column (480)?	No	Volume >= 80% column (160)?	No		
Condition B	Volume >= 100% column (900)?	No	Volume >= 100% column (100)?	Yes		
	Volume >= 80% column (720)?	No	Volume >= 80% column (80)?	Yes		

18:45 to 19:45	374	146	No	No	No	No
Condition A	Volume >= 100% column (600)?	No	Volume >= 100% column (200)?	No		
	Volume >= 80% column (480)?	No	Volume >= 80% column (160)?	No		
Condition B	Volume >= 100% column (900)?	No	Volume >= 100% column (100)?	Yes		
	Volume >= 80% column (720)?	No	Volume >= 80% column (80)?	Yes		

19:00 to 20:00	320	132	No	No	No	No
Condition A	Volume >= 100% column (600)?	No	Volume >= 100% column (200)?	No		
	Volume >= 80% column (480)?	No	Volume >= 80% column (160)?	No		
Condition B	Volume >= 100% column (900)?	No	Volume >= 100% column (100)?	Yes		
	Volume >= 80% column (720)?	No	Volume >= 80% column (80)?	Yes		

19:15 to 20:15	281	119	No	No	No	No
Condition A	Volume >= 100% column (600)?	No	Volume >= 100% column (200)?	No		
	Volume >= 80% column (480)?	No	Volume >= 80% column (160)?	No		
Condition B	Volume >= 100% column (900)?	No	Volume >= 100% column (100)?	Yes		
	Volume >= 80% column (720)?	No	Volume >= 80% column (80)?	Yes		

19:30 to 20:30	258	108	No	No	No	No
Condition A	Volume >= 100% column (600)?	No	Volume >= 100% column (200)?	No		
	Volume >= 80% column (480)?	No	Volume >= 80% column (160)?	No		
Condition B	Volume >= 100% column (900)?	No	Volume >= 100% column (100)?	Yes		
	Volume >= 80% column (720)?	No	Volume >= 80% column (80)?	Yes		

19:45 to 20:45	233	100	No	No	No	No
Condition A	Volume >= 100% column (600)?	No	Volume >= 100% column (200)?	No		
	Volume >= 80% column (480)?	No	Volume >= 80% column (160)?	No		
Condition B	Volume >= 100% column (900)?	No	Volume >= 100% column (100)?	Yes		
	Volume >= 80% column (720)?	No	Volume >= 80% column (80)?	Yes		

20:00 to 21:00	205	93	No	No	No	No
Condition A	Volume >= 100% column (600)?	No	Volume >= 100% column (200)?	No		
	Volume >= 80% column (480)?	No	Volume >= 80% column (160)?	No		
Condition B	Volume >= 100% column (900)?	No	Volume >= 100% column (100)?	No		
	Volume >= 80% column (720)?	No	Volume >= 80% column (80)?	Yes		

20:15 to 21:15	178	78	No	No	No	No
Condition A	Volume >= 100% column (600)?	No	Volume >= 100% column (200)?	No		
	Volume >= 80% column (480)?	No	Volume >= 80% column (160)?	No		
Condition B	Volume >= 100% column (900)?	No	Volume >= 100% column (100)?	No		
	Volume >= 80% column (720)?	No	Volume >= 80% column (80)?	No		

20:30 to 21:30	166	66	No	No	No	No
Condition A	Volume >= 100% column (600)?	No	Volume >= 100% column (200)?	No		
	Volume >= 80% column (480)?	No	Volume >= 80% column (160)?	No		
Condition B	Volume >= 100% column (900)?	No	Volume >= 100% column (100)?	No		
	Volume >= 80% column (720)?	No	Volume >= 80% column (80)?	No		

20:45 to 21:45	172	62	No	No	No	No
Condition A	Volume >= 100% column (600)?	No	Volume >= 100% column (200)?	No		
	Volume >= 80% column (480)?	No	Volume >= 80% column (160)?	No		
Condition B	Volume >= 100% column (900)?	No	Volume >= 100% column (100)?	No		
	Volume >= 80% column (720)?	No	Volume >= 80% column (80)?	No		

21:00 to 22:00	158	54	No	No	No	No
Condition A	Volume >= 100% column (600)?	No	Volume >= 100% column (200)?	No		
	Volume >= 80% column (480)?	No	Volume >= 80% column (160)?	No		
Condition B	Volume >= 100% column (900)?	No	Volume >= 100% column (100)?	No		
	Volume >= 80% column (720)?	No	Volume >= 80% column (80)?	No		

21:15 to 22:15	141	46	No	No	No	No
Condition A	Volume >= 100% column (600)?	No	Volume >= 100% column (200)?	No		
	Volume >= 80% column (480)?	No	Volume >= 80% column (160)?	No		
Condition B	Volume >= 100% column (900)?	No	Volume >= 100% column (100)?	No		
	Volume >= 80% column (720)?	No	Volume >= 80% column (80)?	No		

21:30 to 22:30	122	45	No	No	No	No
Condition A	Volume >= 100% column (600)?	No	Volume >= 100% column (200)?	No		
	Volume >= 80% column (480)?	No	Volume >= 80% column (160)?	No		
Condition B	Volume >= 100% column (900)?	No	Volume >= 100% column (100)?	No		
	Volume >= 80% column (720)?	No	Volume >= 80% column (80)?	No		

21:45 to 22:45	85	39	No	No	No	No
Condition A	Volume >= 100% column (600)?	No	Volume >= 100% column (200)?	No		
	Volume >= 80% column (480)?	No	Volume >= 80% column (160)?	No		
Condition B	Volume >= 100% column (900)?	No	Volume >= 100% column (100)?	No		
	Volume >= 80% column (720)?	No	Volume >= 80% column (80)?	No		

22:00 to 23:00	74	37	No	No	No	No
Condition A	Volume >= 100% column (600)?	No	Volume >= 100% column (200)?	No		
	Volume >= 80% column (480)?	No	Volume >= 80% column (160)?	No		
Condition B	Volume >= 100% column (900)?	No	Volume >= 100% column (100)?	No		
	Volume >= 80% column (720)?	No	Volume >= 80% column (80)?	No		

22:15 to 23:15	68	37	No	No	No	No
Condition A	Volume >= 100% column (600)?	No	Volume >= 100% column (200)?	No		
	Volume >= 80% column (480)?	No	Volume >= 80% column (160)?	No		
Condition B	Volume >= 100% column (900)?	No	Volume >= 100% column (100)?	No		
	Volume >= 80% column (720)?	No	Volume >= 80% column (80)?	No		

22:30 to 23:30	63	29	No	No	No	No
Condition A	Volume >= 100% column (600)?	No	Volume >= 100% column (200)?	No		
	Volume >= 80% column (480)?	No	Volume >= 80% column (160)?	No		
Condition B	Volume >= 100% column (900)?	No	Volume >= 100% column (100)?	No		
	Volume >= 80% column (720)?	No	Volume >= 80% column (80)?	No		

22:45 to 23:45	59	23	No	No	No	No
Condition A	Volume >= 100% column (600)?	No	Volume >= 100% column (200)?	No		
	Volume >= 80% column (480)?	No	Volume >= 80% column (160)?	No		
Condition B	Volume >= 100% column (900)?	No	Volume >= 100% column (100)?	No		
	Volume >= 80% column (720)?	No	Volume >= 80% column (80)?	No		

23:00 to 00:00	47	19	No	No	No	No
Condition A	Volume >= 100% column (600)?	No	Volume >= 100% column (200)?	No		
	Volume >= 80% column (480)?	No	Volume >= 80% column (160)?	No		
Condition B	Volume >= 100% column (900)?	No	Volume >= 100% column (100)?	No		
	Volume >= 80% column (720)?	No	Volume >= 80% column (80)?	No		

23:15 to 00:15	38	14	No	No	No	No
Condition A	Volume >= 100% column (600)?	No	Volume >= 100% column (200)?	No		
	Volume >= 80% column (480)?	No	Volume >= 80% column (160)?	No		
Condition B	Volume >= 100% column (900)?	No	Volume >= 100% column (100)?	No		
	Volume >= 80% column (720)?	No	Volume >= 80% column (80)?	No		

23:30 to 00:30		26	10	No	No	No	No
Condition A	Volume >= 100% column (600)?	No	Volume >= 100% column (200)?	No			
	Volume >= 80% column (480)?	No	Volume >= 80% column (160)?	No			
Condition B	Volume >= 100% column (900)?	No	Volume >= 100% column (100)?	No			
	Volume >= 80% column (720)?	No	Volume >= 80% column (80)?	No			

23:45 to 00:45		19	10	No	No	No	No
Condition A	Volume >= 100% column (600)?	No	Volume >= 100% column (200)?	No			
	Volume >= 80% column (480)?	No	Volume >= 80% column (160)?	No			
Condition B	Volume >= 100% column (900)?	No	Volume >= 100% column (100)?	No			
	Volume >= 80% column (720)?	No	Volume >= 80% column (80)?	No			

Warrant 2: Four-hour Vehicular Volume

1: Swanson Ave & Smoketree Ave

Intersection Information:

	Major Street	Minor Street
Street Name	Swanson Ave	Smoketree Ave
Direction	EB/WB	NB/SB
Number of Lanes	2	2
Approach Speed	30	35

Warrant 2 Met? Yes

Details:

Notes	5 Hours met (4 required)
Low population?	No

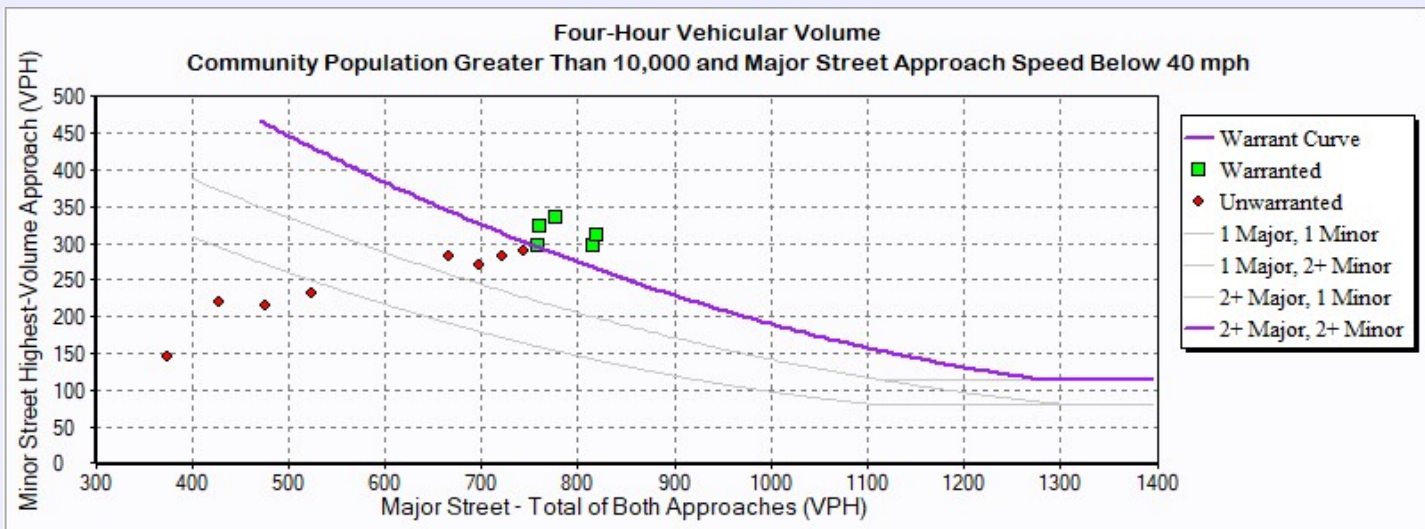

Hourly Volumes

Hour	Major Street Total All Approaches (vph)	Minor Street Highest Volume Approach (vph)
00:00:00 - 01:00:00	18.00	8.00
01:00:00 - 02:00:00	15.00	5.00
02:00:00 - 03:00:00	22.00	3.00
03:00:00 - 04:00:00	12.00	4.00
04:00:00 - 05:00:00	49.00	19.00
05:00:00 - 06:00:00	99.00	65.00
06:00:00 - 07:00:00	202.00	83.00
07:00:00 - 08:00:00	429.00	220.00
08:00:00 - 09:00:00	524.00	233.00
09:00:00 - 10:00:00	697.00	271.00
10:00:00 - 11:00:00	744.00	290.00
11:00:00 - 12:00:00	771.00	320.00
12:00:00 - 13:00:00	798.00	295.00
13:00:00 - 14:00:00	800.00	297.00
14:00:00 - 15:00:00	782.00	337.00
15:00:00 - 16:00:00	753.00	316.00
16:00:00 - 17:00:00	705.00	275.00
17:00:00 - 18:00:00	647.00	288.00
18:00:00 - 19:00:00	461.00	179.00
19:00:00 - 20:00:00	320.00	132.00
20:00:00 - 21:00:00	205.00	93.00
21:00:00 - 22:00:00	158.00	54.00
22:00:00 - 23:00:00	74.00	37.00
23:00:00 - 00:00:00	47.00	19.00

Warranted Volumes

Hour	Major Street Total All Approaches (vph)	Minor Street Highest Volume Approach (vph)
10:45:00 - 11:45:00	760.00	324.00
11:45:00 - 12:45:00	816.00	298.00
12:45:00 - 13:45:00	758.00	297.00
13:45:00 - 14:45:00	819.00	312.00
14:45:00 - 15:45:00	778.00	335.00

Warrant 7: Crash Experience

1: Swanson Ave & Smoketree Ave

Intersection Information:

Major Street Name Swanson Ave
 Major Street Direction EB/WB
 Minor Street Direction NB/SB

WARRANT 7 MET? No

Details:

Low Population? **No** Traffic Volume Condition Met? **Yes**
 Major Street Speed Limit 30 11 Hours Met (8 Required)
 Major Street 85th-% tile Speed 30.00 Ped Volume Condition Met? **No**
 0 Hours Met (8 Required)
 Qualifying Crashes **2**
 Adequate Alternative Trials? **No**

Hour	Traffic Volumes				Pedestrian Volumes			
	Major Street Vehicles	Minor Street Vehicles	80% Standard Met? A or B		Northbound Ped Volumes		Southbound Ped Volumes	
			Condition A	Condition B	Peds	> 80?	Peds	> 80?
00:00 to 01:00	18	8	No	No	0	No	0	No
00:15 to 01:15	19	6	No	No	0	No	0	No
00:30 to 01:30	16	5	No	No	0	No	0	No
00:45 to 01:45	16	4	No	No	0	No	0	No
01:00 to 02:00	15	5	No	No	0	No	0	No
01:15 to 02:15	18	4	No	No	0	No	0	No
01:30 to 02:30	20	3	No	No	0	No	0	No

01:45 to 02:45	20	2	No	No	0	No	0	No
02:00 to 03:00	22	3	No	No	0	No	0	No
02:15 to 03:15	14	3	No	No	0	No	0	No
02:30 to 03:30	10	6	No	No	0	No	0	No
02:45 to 03:45	11	5	No	No	0	No	0	No
03:00 to 04:00	12	4	No	No	0	No	0	No
03:15 to 04:15	16	7	No	No	0	No	0	No
03:30 to 04:30	26	10	No	No	0	No	0	No
03:45 to 04:45	31	12	No	No	0	No	0	No
04:00 to 05:00	49	19	No	No	1	No	0	No
04:15 to 05:15	60	26	No	No	1	No	0	No
04:30 to 05:30	70	38	No	No	1	No	0	No
04:45 to 05:45	80	53	No	No	1	No	0	No
05:00 to 06:00	99	65	No	No	0	No	0	No
05:15 to 06:15	126	77	No	No	0	No	0	No
05:30 to 06:30	149	77	No	No	1	No	0	No
05:45 to 06:45	185	76	No	No	2	No	0	No

06:00 to 07:00	202	83	No	No	2	No	1	No
06:15 to 07:15	219	90	No	No	2	No	1	No
06:30 to 07:30	267	119	No	No	1	No	1	No
06:45 to 07:45	311	169	No	No	1	No	1	No
07:00 to 08:00	429	220	No	No	2	No	0	No
07:15 to 08:15	511	247	Yes*	No*	2	No	0	No
07:30 to 08:30	526	254	Yes	No	4	No	2	No
07:45 to 08:45	544	247	Yes	No	6	No	2	No
08:00 to 09:00	524	233	Yes	No	7	No	2	No
08:15 to 09:15	540	226	Yes*	No*	7	No	2	No
08:30 to 09:30	610	236	Yes	No	5	No	0	No
08:45 to 09:45	657	245	Yes	No	3	No	0	No
09:00 to 10:00	697	271	Yes	No	2	No	1	No
09:15 to 10:15	721	287	Yes*	Yes*	2	No	1	No
09:30 to 10:30	725	294	Yes	Yes	3	No	1	No
09:45 to 10:45	741	291	Yes	Yes	3	No	1	No
10:00 to 11:00	744	290	Yes	Yes	4	No	0	No

10:15 to 11:15	728	307	Yes*	Yes*	4	No	0	No
10:30 to 11:30	735	301	Yes	Yes	4	No	0	No
10:45 to 11:45	760	324	Yes	Yes	3	No	0	No
11:00 to 12:00	771	320	Yes	Yes	2	No	0	No
11:15 to 12:15	832	314	Yes*	Yes*	2	No	0	No
11:30 to 12:30	826	324	Yes	Yes	1	No	0	No
11:45 to 12:45	816	298	Yes	Yes	1	No	0	No
12:00 to 13:00	798	295	Yes	Yes	0	No	0	No
12:15 to 13:15	777	300	Yes*	Yes*	0	No	0	No
12:30 to 13:30	778	290	Yes	Yes	1	No	0	No
12:45 to 13:45	758	297	Yes	Yes	1	No	0	No
13:00 to 14:00	800	297	Yes	Yes	1	No	0	No
13:15 to 14:15	797	286	Yes*	Yes*	1	No	0	No
13:30 to 14:30	825	292	Yes	Yes	0	No	1	No
13:45 to 14:45	819	312	Yes	Yes	0	No	1	No
14:00 to 15:00	782	337	Yes	Yes	0	No	1	No
14:15 to 15:15	791	351	Yes*	Yes*	0	No	1	No

14:30 to 15:30	764	356	Yes	Yes	1	No	0	No
14:45 to 15:45	778	335	Yes	Yes	1	No	0	No
15:00 to 16:00	753	316	Yes	Yes	1	No	0	No
15:15 to 16:15	724	299	Yes*	Yes*	1	No	0	No
15:30 to 16:30	722	286	Yes	Yes	0	No	0	No
15:45 to 16:45	721	283	Yes	Yes	2	No	0	No
16:00 to 17:00	705	275	Yes	No	2	No	0	No
16:15 to 17:15	728	287	Yes*	Yes*	2	No	0	No
16:30 to 17:30	693	295	Yes	No	3	No	0	No
16:45 to 17:45	666	283	Yes	No	2	No	0	No
17:00 to 18:00	647	288	Yes	No	2	No	2	No
17:15 to 18:15	566	273	Yes*	No*	2	No	3	No
17:30 to 18:30	534	228	Yes	No	2	No	3	No
17:45 to 18:45	476	215	No	No	2	No	4	No
18:00 to 19:00	461	179	No	No	3	No	2	No
18:15 to 19:15	439	165	No	No	3	No	1	No
18:30 to 19:30	401	156	No	No	2	No	1	No

18:45 to 19:45	374	146	No	No	1	No	0	No
19:00 to 20:00	320	132	No	No	0	No	0	No
19:15 to 20:15	281	119	No	No	0	No	0	No
19:30 to 20:30	258	108	No	No	0	No	0	No
19:45 to 20:45	233	100	No	No	0	No	0	No
20:00 to 21:00	205	93	No	No	0	No	0	No
20:15 to 21:15	178	78	No	No	0	No	0	No
20:30 to 21:30	166	66	No	No	0	No	0	No
20:45 to 21:45	172	62	No	No	0	No	0	No
21:00 to 22:00	158	54	No	No	0	No	0	No
21:15 to 22:15	141	46	No	No	0	No	0	No
21:30 to 22:30	122	45	No	No	0	No	0	No
21:45 to 22:45	85	39	No	No	1	No	0	No
22:00 to 23:00	74	37	No	No	1	No	0	No
22:15 to 23:15	68	37	No	No	1	No	0	No
22:30 to 23:30	63	29	No	No	1	No	0	No
22:45 to 23:45	59	23	No	No	0	No	0	No

23:00 to 00:00	47	19	No	No	0	No	0	No
23:15 to 00:15	38	14	No	No	0	No	0	No
23:30 to 00:30	26	10	No	No	0	No	0	No
23:45 to 00:45	19	10	No	No	0	No	0	No

ATTACHMENT F

May 21, 2026

Mr. Ryan Garland
 Paradyme Investments LLC
 43620 Ridge Park Drive, Suite 310
 Temecula, CA 92590

Re: Paradyme Flats | Traffic Impact Statement
 Initial Report Response to Comments

Greenlight Traffic Engineering, LLC (Greenlight) has prepared our response to comments (RTC) for comments from Lake Havasu City, dated May 1, 2026. This response to comments will be included in the updated report as an appendix.

Disposition Code:

A = Will Comply B = Agency to Evaluate C = Consultant to Evaluate D = No Action Recommended

No.	Sheet or Section	Comment	Disposition Code	Greenlight Response
City of Avondale, Development Services				
1	General	The report states that Signal Warrant 7 was met. Staff requests clarification on whether Signal Warrants 1 and 2 are met under existing conditions, are triggered solely by project-generated traffic, or if only Warrant 7 applies.	A	The report has been updated to clarify the traffic signal warrant analysis findings. Signal Warrants 1 and 2 are met under existing traffic conditions, independent of the proposed Project. Warrant 7 was evaluated and Criteria B and C are met based on existing crash history and traffic volumes; Criteria A (adequate trial of alternatives) was not evaluated as part of this TIS, as it requires trials, observations, and enforcement at the intersection.
2	General	Please verify, using an operational analysis, that the proposed project does not cause a decrease in the Level of Service (LOS) for any movement on any leg of the existing multi-lane, four-way stop-controlled intersection.	A	A Level of Service (LOS) analysis has been added to the report for the Swanson Avenue/Smoketree Avenue all-way stop-controlled intersection. The analysis was performed for the Year 2027 AM and PM peak hours under both non-site and total traffic conditions. As shown in Table 7, the intersection maintains its respective LOS results under both scenarios, and the Project does not cause a decrease in LOS for any movement at the intersection.
3	General	Staff requests a professional discussion of the expected resident decision-making and traffic distribution patterns for the development. This should include reasonable assumptions regarding how residents may choose ingress and egress routes, including the likelihood of avoiding certain intersections or stop-controlled approaches.	A	A discussion of expected resident decision-making and traffic distribution patterns has been added to the Trip Distribution and Assignment section (Section 4.3).